

THIS DOCUMENT IS THE PROPERTY OF
KEYSTONE ELECTRONICS CORP. AND
SHALL NOT BE REPRODUCED, DISTRIBUTED
OR USED AS A BASIS FOR MANUFACTURE
WITHOUT PRIOR WRITTEN PERMISSION
FROM KEYSTONE ELECTRONICS CORP.

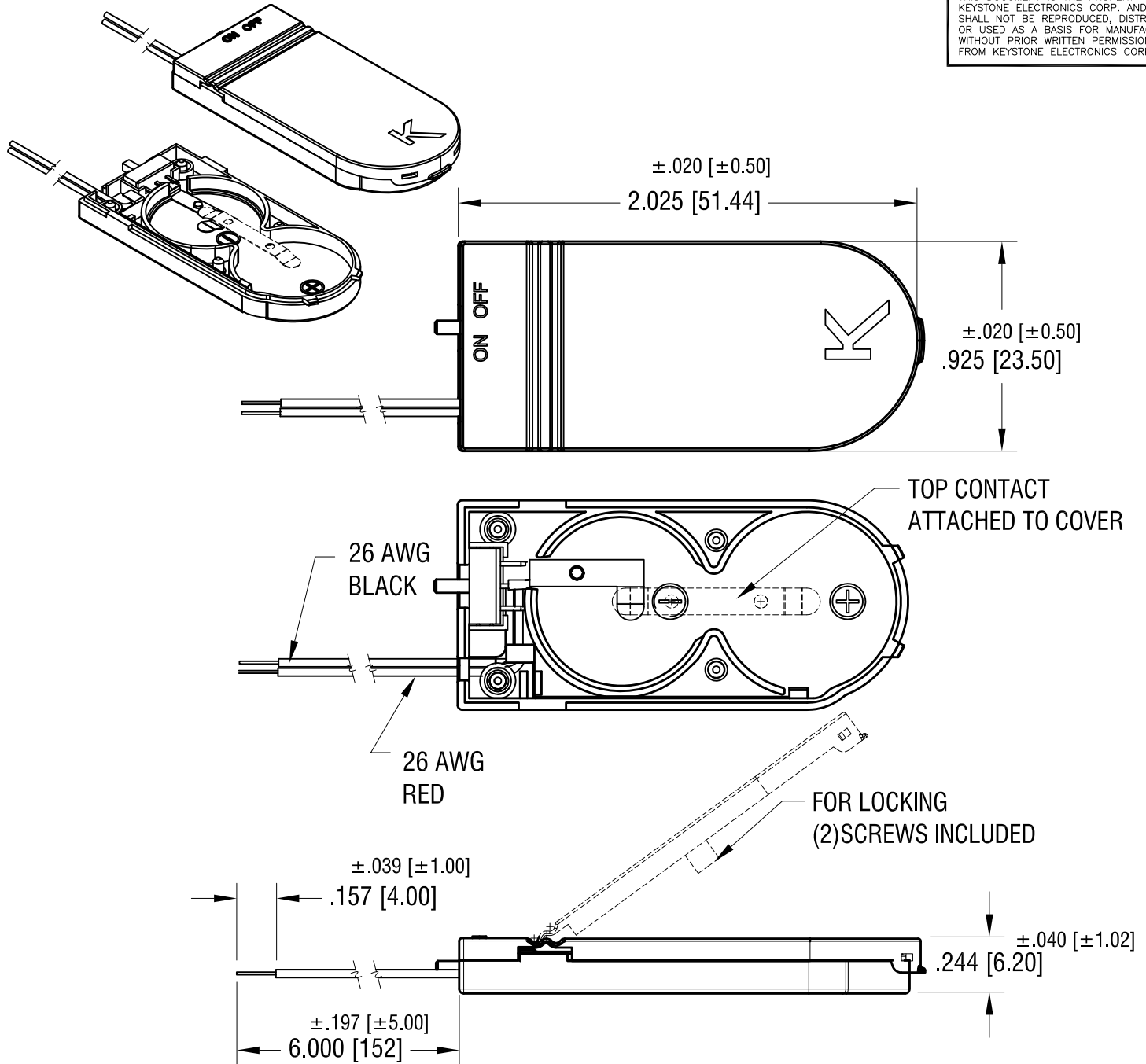

NOTE:

1. HOLDER: MAT'L: POLYPROPYLENE
2. POSITIVE AND NEGATIVE CONTACT:
MAT'L- .006 [0.15] TH'K PHOSPHOR BRONZE
FINISH- NICKEL PLATE
3. WIRE: 26 AWG, UL/CSA 1007
4. (2) SCREWS SUPPLIED LOOSE.
MAT'L: STEEL, NICKEL PLATE

KEYSTONE ELECTRONICS CORP.			
www.keyelco.com • NEW HYDE PARK, NY 11040 • Tel (516) 328-7500			
PART NAME			
2032 CELL (2) HOLDER WITH SWITCH			
MATERIAL			
AS NOTED			
FINISH		DRN BY	DATE
AS NOTED		NT	12.19.19
		APP'D	SCALE
		RH	1.5X
TOLERANCES	INCH	[MM]	CODE
DECIMAL	±.010	[±.025]	C
ANGULAR	± 1°		DWG NO.
UNLESS OTHERWISE SPECIFIED			1092

DATE	DESCRIPTION	REV.