

ezyLED 12V AC 3030 EMC AB-EZP Series

ezyLED reduces driving circuit dramatically. All ezyLEDs are connected in parallel, and directly driven by a conventional 12V AC/DC voltage source without the needs of the driver IC and passive components. With ezyLED so easy to use, users only have to focus on the design of the lamps. Inventory management of components is minimized.



AB-EZP products operate over a wide voltage range (Figure 3). Luminous intensity remains constant for $10.4V < V_{in} < 24V$, and maintains approximately 50% of its nominal value when input voltage drops to 9 volts.

AB-EZP products support over temperature protection (OTP) by reducing input current and hence the luminous intensity when the device temperature exceeds $120^{\circ}C$ (Figure 2). For long-term reliability, sufficient heat dissipation mechanism in lamp design is required to ensure ezyLED operates in the rated temperature range ($-40^{\circ}C \sim 85^{\circ}C$).



Features

- Patented LED chip design with built-in driving IC
- Using conventional 12V AC/DC voltage sources
- All ezyLEDs connected in parallel
- Luminance and Correlated color temperature (CCT) remain constant while the input voltage varies over an extensive range
- Built-in rectification for non-polar applications
- Over temperature protection

Application

- Automotive lighting
- Architectural lighting
- General lighting
- Down light
- Landscape lighting

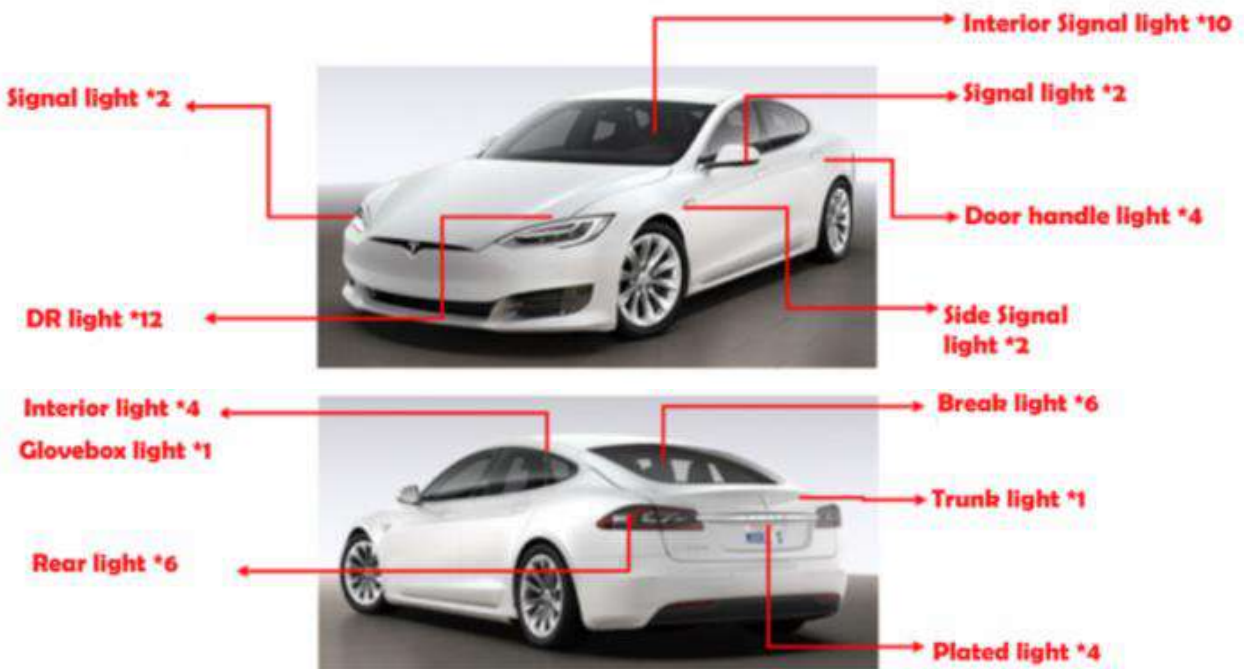

General Characteristics (Ta=25°C @ Vin =12V)

Parameters	Symbol	Min.	Typ.	Max.	Unit
Luminous Flux@20mA (0.3W)	Φ_v		30		lm
Luminous Flux@50mA (0.5W)	Φ_v		60		lm
Luminous Flux@100mA (1.0W)	Φ_v		110		lm
Luminous Flux@110mA (Red)	Φ_v	39	42	44	lm
Luminous Flux@110mA (Green)	Φ_v	71	75	79	lm
Luminous Flux@110mA (Blue)	Φ_v	25	26	27	lm
Viewing Angle (FWHM)	$2\theta_{1/2}$		120		degree
Thermal Resistance (Junction to slug)	R_{th}		15		°C/W

Absolute Maximum Ratings

Parameters	Symbol	Min.	Typ.	Max.	Unit
Rated Voltage	Vin	10.5	12	24	Vdc
Reverse Voltage				15	Vdc
LED Junction Temperature	T _J			120	°C
Operation Temperature Range	T _c	-40		85	°C
ESD@HBM	ESDHBM			4K	V
Allowable Reflow cycles	-			3	cycles
Storage Temperature Range	-	-40		100	°C

Notes :

Parts are tested in pulsed conditions, T_a=25°C.

Pulse width is 10ms at rated voltage.

Tolerance of Luminous Intensity: ±10%

Maximum Temperature at solder pads (T_c) during operation: 85°C

The lifetime will be decreased if the operation temperature exceeds the maximum value.

Ordering Information

Color	CCT/Wavelength		CRI	Power	Light Output (Typ)		Part number
	Min	Max			Ta=25°C	Tc=85°C	
Red	620nm	630nm	NA	0.3	9 lm	7 lm	AB-EZP03R-A3
Green	520nm	530nm	NA	0.3	17 lm	15 lm	AB-EZP03G-A3
Blue	445nm	465nm	NA	0.3	6 lm	5 lm	AB-EZP03B-A3
Cool White	7000K	9000K	70	0.5	55 lm	45 lm	AB-EZP05C-A3-K80
Cool White	6000K	7000K	70	0.5	55 lm	45 lm	AB-EZP05C-A3-K65
Cool White	5400K	6000K	70	0.5	55 lm	45 lm	AB-EZP05C-A3-K57
Neutral White	3725K	4275K	70	0.5	55 lm	45 lm	AB-EZP05N-A3-K40
Warm White	2850K	3150K	80	0.5	55 lm	45 lm	AB-EZP05W-A3-K30
Warm White	2650K	2850K	80	0.5	55 lm	45 lm	AB-EZP05W-A3-K27
Amber	1800K		NA	0.5	35 lm	25 lm	AB-EZP05A-A3-K18
Amber	1300K		NA	0.5	35 lm	25 lm	AB-EZP05A-A3-K13
Red	620nm	630nm	NA	0.6	20 lm	16 lm	AB-EZP06R-A3
Green	520nm	530nm	NA	0.6	35 lm	31 lm	AB-EZP06G-A3
Blue	445nm	465nm	NA	0.6	12 lm	11 lm	AB-EZP06B-A3
Cool White	7000K	9000K	70	1.0	110 lm	90 lm	AB-EZP10C-A3-K80
Cool White	6000K	7000K	70	1.0	110 lm	90 lm	AB-EZP10C-A3-K65
Cool White	5400K	6000K	70	1.0	110 lm	90 lm	AB-EZP10C-A3-K57
Neutral White	3725K	4275K	70	1.0	110 lm	90 lm	AB-EZP10N-A3-K40
Warm White	2850K	3150K	80	1.0	110 lm	90 lm	AB-EZP10W-A3-K30
Warm White	2650K	2850K	80	1.0	110 lm	90 lm	AB-EZP10W-A3-K27
Amber	1800K		NA	1.0	65 lm	50 lm	AB-EZP10A-A3-K18
Amber	1300K		NA	1.0	65 lm	50 lm	AB-EZP10A-A3-K13
Red	620nm	630nm	NA	1.3	39 lm	32 lm	AB-EZP13R-A3
Green	520nm	530nm	NA	1.3	71 lm	64 lm	AB-EZP13G-A3
Blue	445nm	465nm	NA	1.3	25 lm	22 lm	AB-EZP13B-A3
Cool White	7000K	9000K	70	2.4	210 lm	170 lm	AB-EZP24C-A3-K80
Cool White	6000K	7000K	70	2.4	210 lm	170 lm	AB-EZP24C-A3-K65
Cool White	5400K	6000K	70	2.4	210 lm	170 lm	AB-EZP24C-A3-K57
Neutral White	3725K	4275K	70	2.4	210 lm	170 lm	AB-EZP24N-A3-K40
Warm White	2850K	3150K	80	2.4	210 lm	170 lm	AB-EZP24W-A3-K30
Warm White	2650K	2850K	80	2.4	210 lm	170 lm	AB-EZP24W-A3-K27

Notes:

Maintains a tolerance of +/-10% on flux measurements and +/-2 on CRI measurements.
Parts are tested in pulsed conditions, Ta=25°C. Pulse width is 10ms at rated test voltage.

Figure 1. Relative Spectral Power Distribution ($V_f=12V_{dc}$)

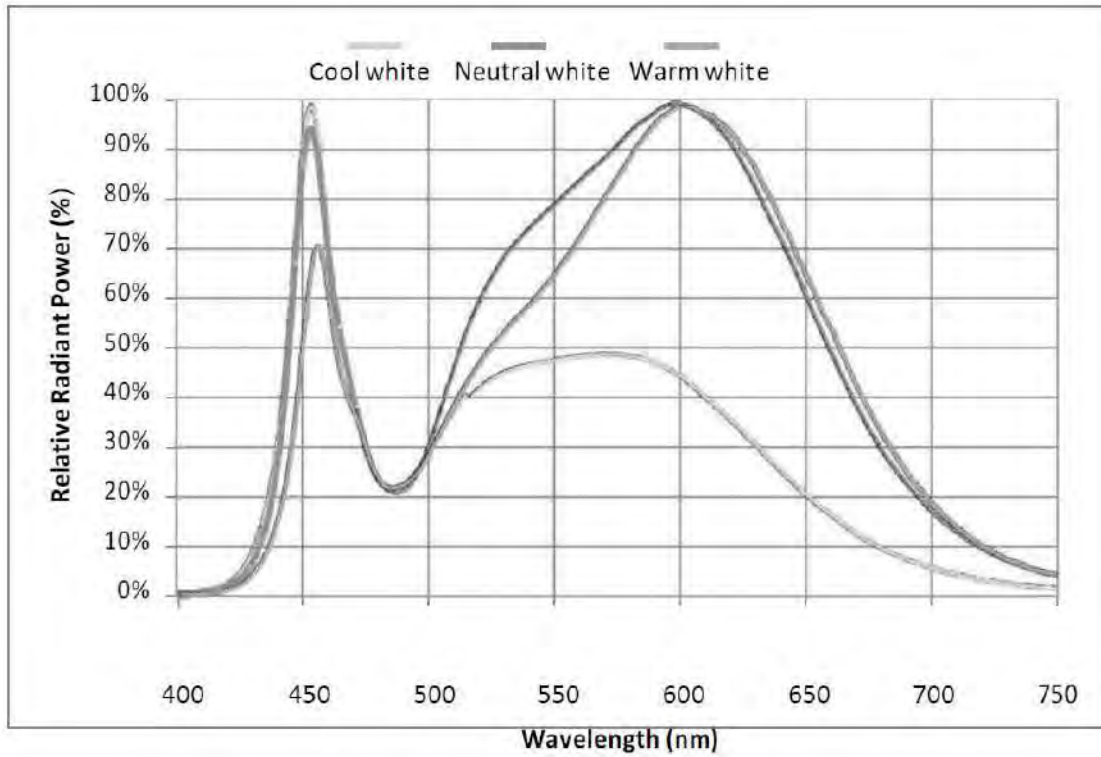

Figure 2 Relative Luminous Flux vs. Temperature (T_c)

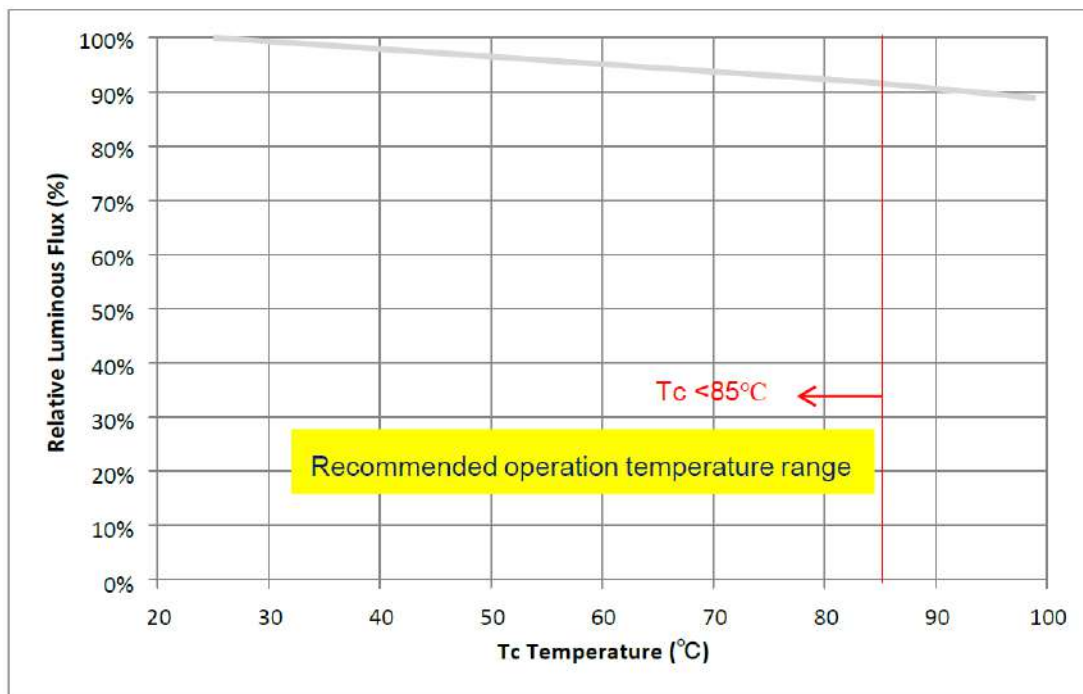

Figure 3 Relative Luminous Flux vs. Operation Voltage (Tc<85°C)

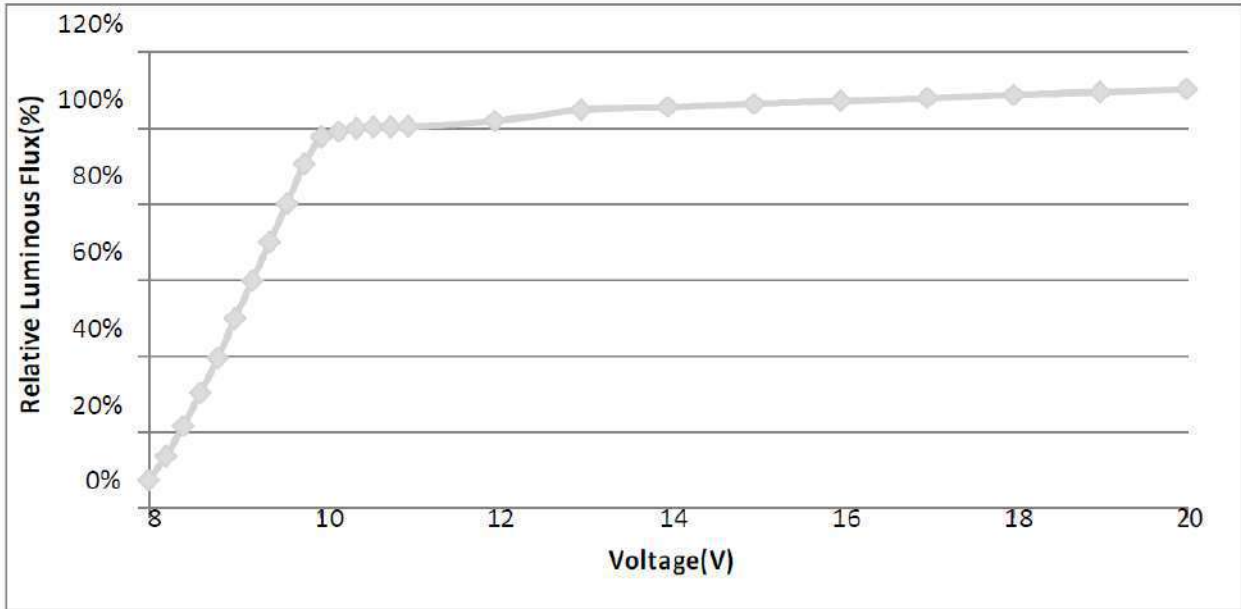

Figure 4 Radiation Diagram

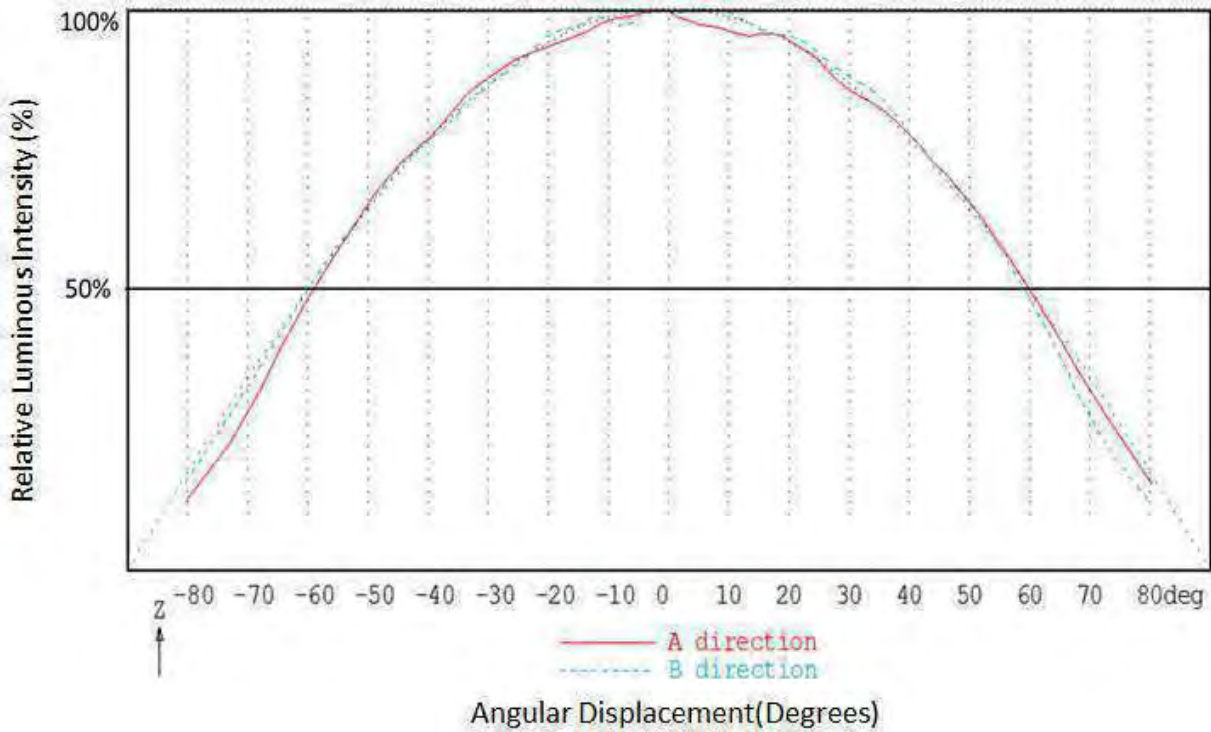

Figure 5 ezyLED ANSI White Bins Plotted on the 1931 CIE Color Space ($T_j=85^\circ\text{C}$)

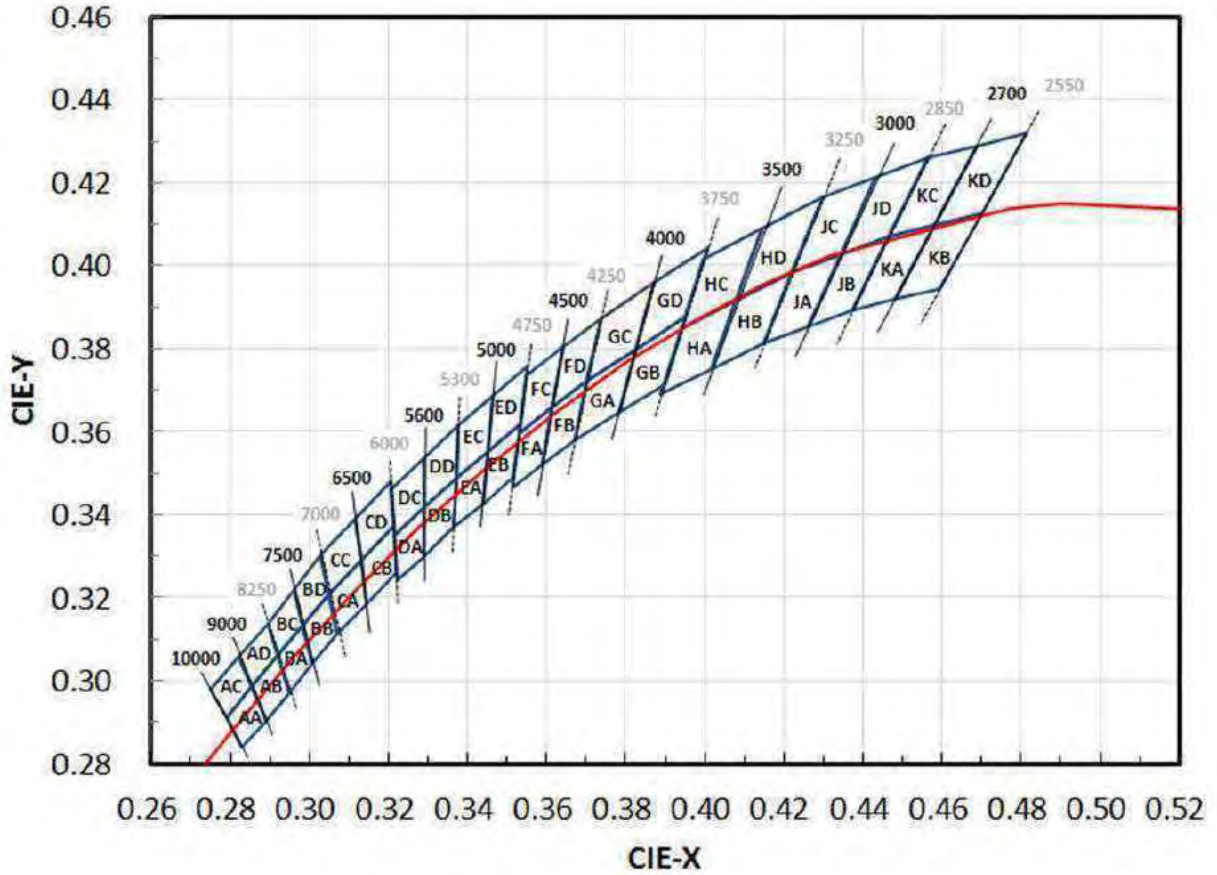
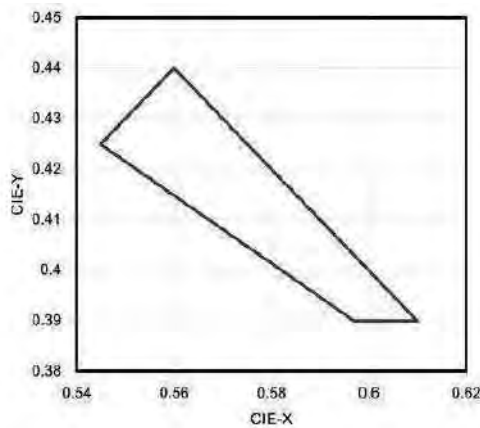

Figure 6 ezyLED PC-amber Plotted on the 1931 CIE Color Space ($T_j=85^\circ\text{C}$)



ezyLED are tested for chromaticity and placed into one of the regions defined by the following bounding coordinates

• **White light product:**

AA	0.2830	0.2840	BA	0.2950	0.2970	CA	0.3068	0.3113	DA	0.3222	0.3243	EA	0.3366	0.3369
	0.2790	0.2910		0.2920	0.3060		0.3048	0.3207		0.3215	0.3350		0.3371	0.3490
	0.2855	0.2985		0.2984	0.3133		0.3130	0.3290		0.3290	0.3417		0.3451	0.3554
	0.2890	0.2905		0.3009	0.3042		0.3144	0.3186		0.3290	0.3300		0.3440	0.3427
	0.2830	0.2840		0.2950	0.2970		0.3068	0.3113		0.3222	0.3243		0.3366	0.3369
AB	0.2890	0.2905	BB	0.3009	0.3042	CB	0.3144	0.3186	DB	0.3290	0.3300	EB	0.3440	0.3427
	0.2855	0.2985		0.2984	0.3133		0.3130	0.3290		0.3290	0.3417		0.3451	0.3554
	0.2920	0.3060		0.3048	0.3207		0.3213	0.3373		0.3371	0.3490		0.3533	0.3620
	0.2950	0.2970		0.3068	0.3113		0.3221	0.3261		0.3366	0.3369		0.3515	0.3487
	0.2890	0.2905		0.3009	0.3042		0.3144	0.3186		0.3290	0.3300		0.3440	0.3427
AC	0.2790	0.2910	BC	0.2920	0.3060	CC	0.3048	0.3207	DC	0.3215	0.3350	EC	0.3371	0.3490
	0.2750	0.2980		0.2895	0.3135		0.3028	0.3304		0.3207	0.3462		0.3376	0.3616
	0.2823	0.3058		0.2962	0.3220		0.3115	0.3391		0.3290	0.3538		0.3463	0.3687
	0.2855	0.2985		0.2984	0.3133		0.3130	0.3290		0.3290	0.3417		0.3451	0.3554
	0.2790	0.2910		0.2920	0.3060		0.3048	0.3207		0.3215	0.3350		0.3371	0.3490
AD	0.2855	0.2985	BD	0.2984	0.3133	CD	0.3130	0.3290	DD	0.3290	0.3417	ED	0.3451	0.3554
	0.2823	0.3058		0.2962	0.3220		0.3115	0.3391		0.3290	0.3538		0.3463	0.3687
	0.2895	0.3135		0.3028	0.3304		0.3205	0.3481		0.3376	0.3616		0.3551	0.3760
	0.2920	0.3060		0.3048	0.3207		0.3213	0.3373		0.3371	0.3490		0.3533	0.3620
	0.2855	0.2985		0.2984	0.3133		0.3130	0.3290		0.3290	0.3417		0.3451	0.3554

FA	0.3512	0.3465	GA	0.3670	0.3578	HA	0.3889	0.3690	JA	0.4147	0.3814	KA	0.4373	0.3893
	0.3530	0.3597		0.3702	0.3722		0.3941	0.3848		0.4221	0.3984		0.4465	0.4071
	0.3615	0.3659		0.3825	0.3798		0.4080	0.3916		0.4342	0.4028		0.4582	0.4099
	0.3590	0.3521		0.3783	0.3646		0.4017	0.3751		0.4259	0.3853		0.4483	0.3919
	0.3512	0.3465		0.3670	0.3578		0.3889	0.3690		0.4147	0.3814		0.4373	0.3893
FB	0.3590	0.3521	GB	0.3783	0.3646	HB	0.4017	0.3751	JB	0.4259	0.3853	KB	0.4483	0.3919
	0.3615	0.3659		0.3825	0.3798		0.4080	0.3916		0.4342	0.4028		0.4582	0.4099
	0.3702	0.3722		0.3950	0.3875		0.4221	0.3984		0.4465	0.4071		0.4700	0.4126
	0.3670	0.3578		0.3898	0.3716		0.4147	0.3814		0.4373	0.3893		0.4593	0.3944
	0.3590	0.3521		0.3783	0.3646		0.4017	0.3751		0.4259	0.3853		0.4483	0.3919
FC	0.3530	0.3597	GC	0.3702	0.3722	HC	0.3941	0.3848	JC	0.4221	0.3984	KC	0.4465	0.4071
	0.3548	0.3736		0.3736	0.3874		0.3996	0.4015		0.4299	0.4165		0.4562	0.4260
	0.3641	0.3804		0.3869	0.3958		0.4146	0.4089		0.4430	0.4212		0.4687	0.4289
	0.3615	0.3659		0.3825	0.3798		0.4080	0.3916		0.4342	0.4028		0.4582	0.4099
	0.3530	0.3597		0.3702	0.3722		0.3941	0.3848		0.4221	0.3984		0.4465	0.4071
FD	0.3615	0.3659	GD	0.3825	0.3798	HD	0.4080	0.3916	JD	0.4342	0.4028	KD	0.4582	0.4099
	0.3641	0.3804		0.3869	0.3958		0.4146	0.4089		0.4430	0.4212		0.4687	0.4289
	0.3736	0.3874		0.4006	0.4044		0.4299	0.4165		0.4562	0.4260		0.4813	0.4319
	0.3702	0.3722		0.3950	0.3875		0.4221	0.3984		0.4465	0.4071		0.4700	0.4126
	0.3615	0.3659		0.3825	0.3798		0.4080	0.3916		0.4342	0.4028		0.4582	0.4099

• **PC-amber product:**

PC-amber	0.56	0.44
	0.54491	0.42491
	0.59701	0.39
	0.61	0.39

Figure 7 Mechanical Dimensions

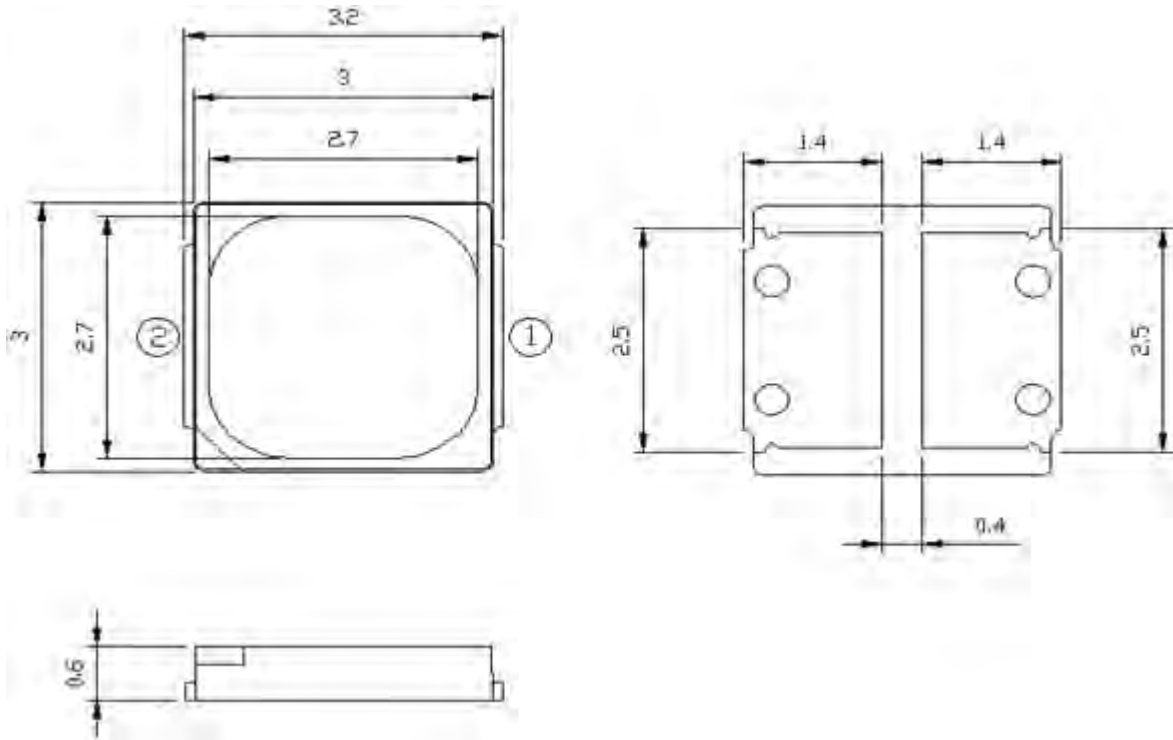

Notes:

1. All dimensions are in mm.
2. Tolerance is +/- 0.1mm unless otherwise specified.
3. Drawings are not to scale.

Figure 8 Block diagram

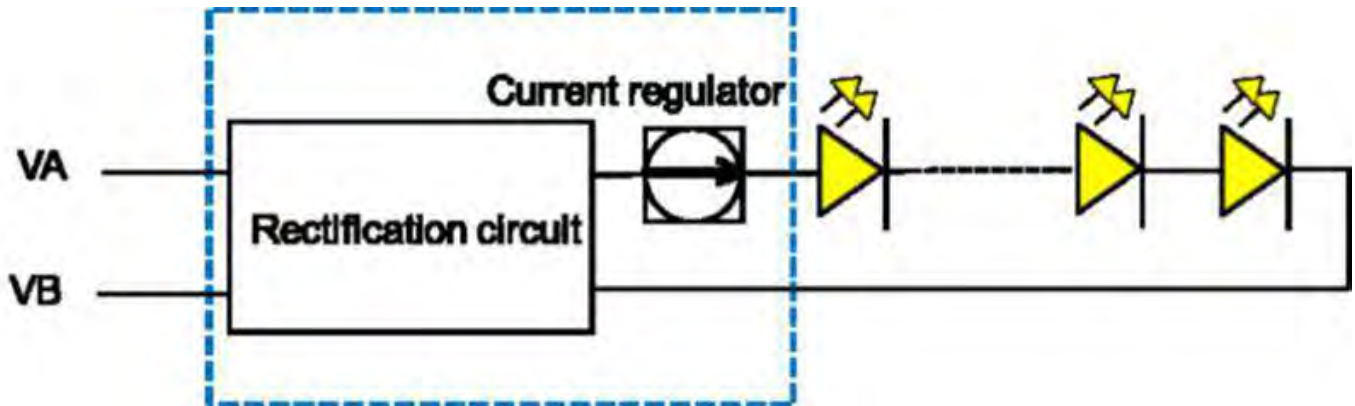
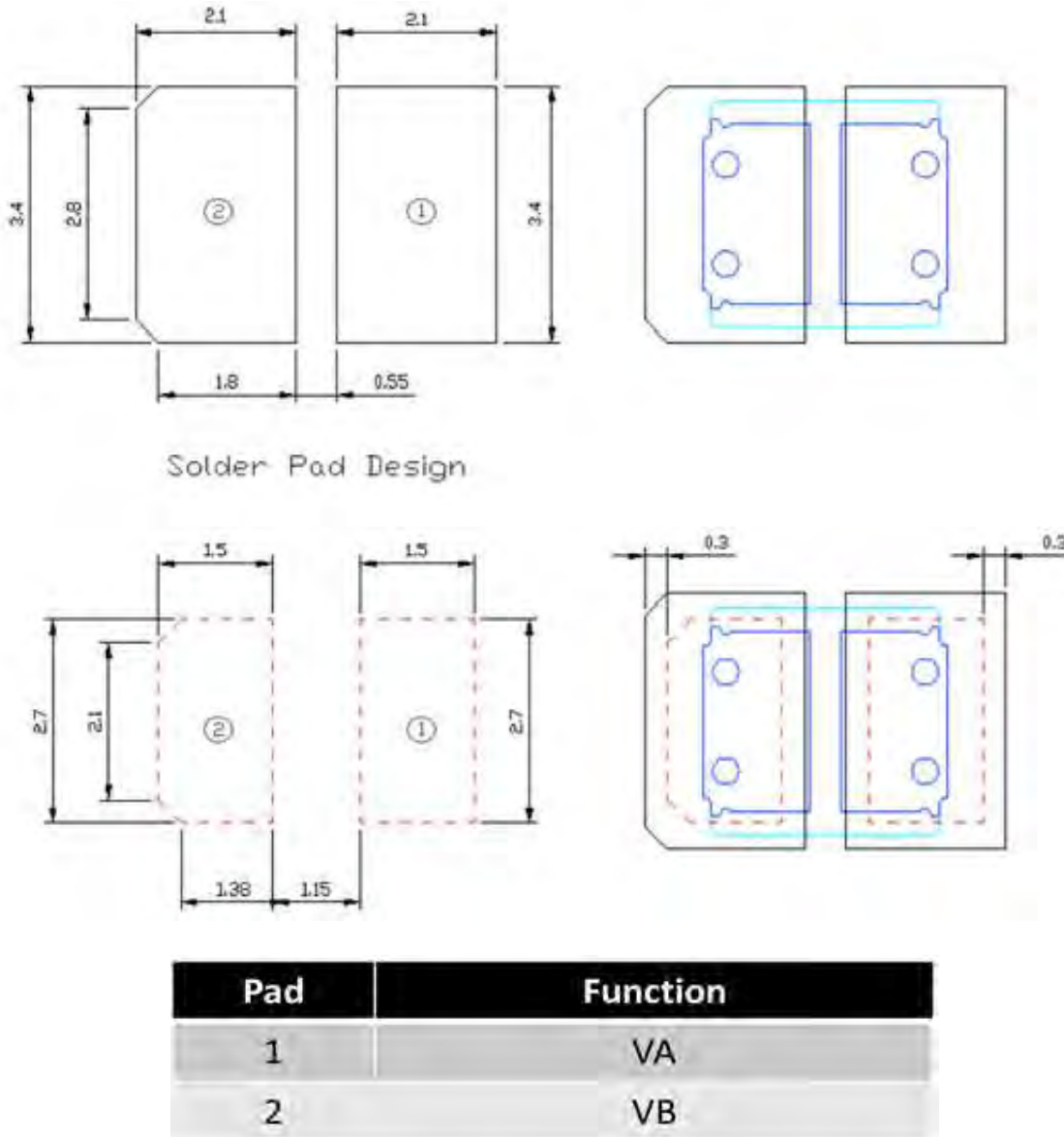

Figure 9 Recommended Solder Pad Dimensions



Notes:

1. All dimensions are in mm.
2. Tolerance is +/- 0.1mm unless otherwise specified.
3. Drawings are not to scale.
4. The other pads on 3030 devices are NC isolated with pad 1&2. (No solder paste)
5. Do not handle 3030 devices by the lens. Incorrect force applied to the lens may lead to the failure .
6. This solder pad dimension could be applied to both lead-frame types of ezyLED.

Figure 10 Application reference

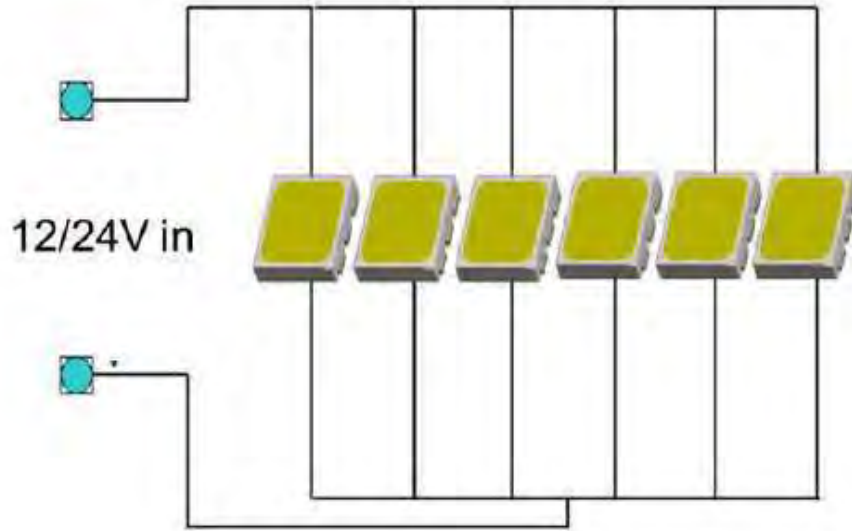

Figure 11 EMC Package

The figure shows a cross-section of an LED package and its final appearance. The cross-section labels include: LED chip, Wire, White epoxy molding compound, Transparent compound, Metal PCB, and Lead frame. The 'Product appearance' shows a small, cylindrical component. Below this, 'After Transfer Molding' shows a tray of multiple packages. At the bottom right, 'A Lighting Blue LED' is shown as a glowing blue circle with a 5mm diameter scale bar.

Cross Section of LED Package

Product appearance

After Transfer Molding

A Lighting Blue LED

CEL-W-Series(7005D1 etc.)

- Long-lasting high reflection
- Good heat and UV resistance
- Applicable for transfer molding including MAP

Figure 12 Soldering Condition (Reference: IPC/JEDEC J-STD-020C)

ezyLED ZE1C series are compatible with IPC/JEDEC J-STD-020C, following the parameters listed below. Recommends that users follow the recommended soldering profile as the general guideline.

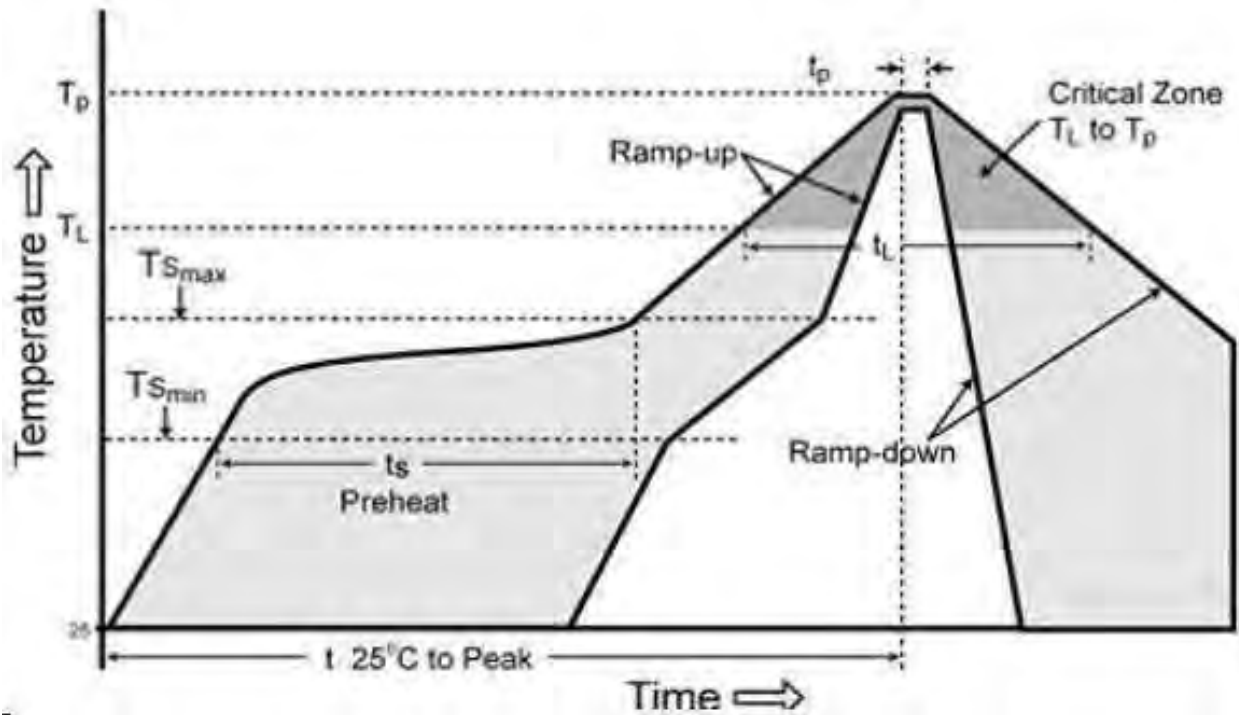

Profile Feature	Pb-Free Assembly
Average ramp-up rate (TL to TP)	3°C/second max.
Preheat	
Temperature Min (Tsmmin)	150°C
Temperature Max (Tsmmax)	200°C
Time (min to max) (ts)	60-180 seconds
Time maintained above:	
Temperature (TL)	217°C
Time (tL)	60-150 seconds
Peak/Classification Temperature (Tp)	240°C
Time within 5°C of actual Peak Temperature (tp)	20-40 seconds
Ramp-down Rate	6°C/second max.
Time 25°C to Peak Temperature	8 minutes max.

Figure 13 Tape and Reel Package

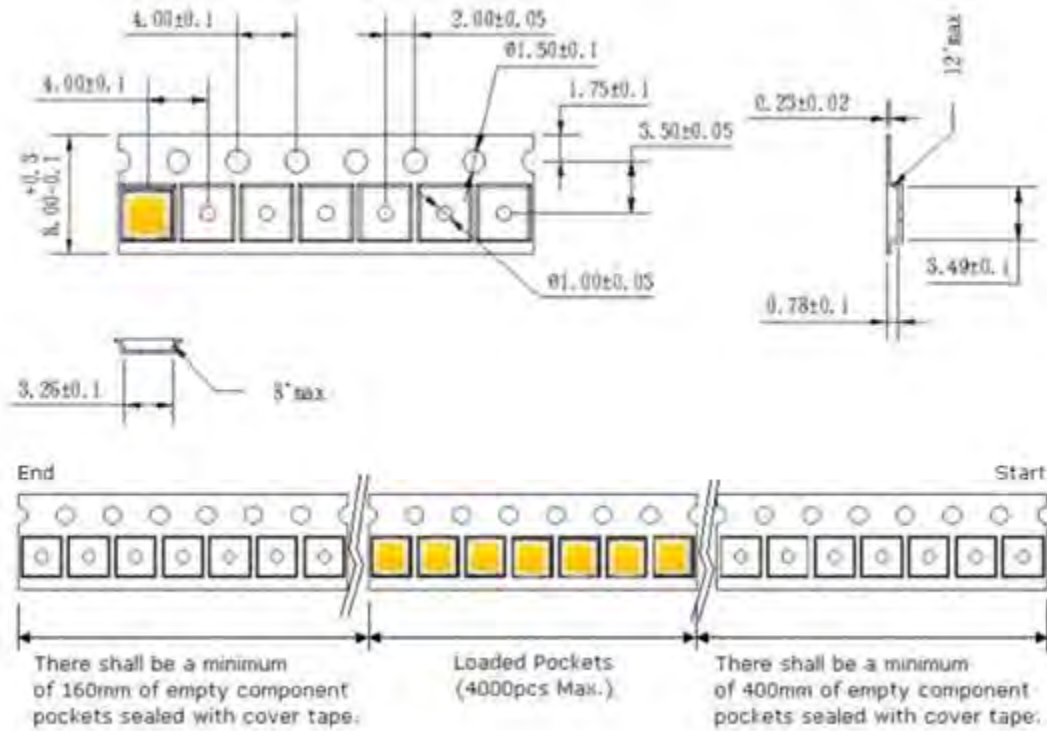

Notes:

Dimensions are in millimeters
Tolerance: ±0.2mm