



COOLTRON[®]
www.cooltron.com



PRODUCT CATALOG

VER.2021





ABOUT COOLTRON



Cooltron Fans

Customer satisfaction is always Cooltron's number one priority. Cooltron values customers' opinions and suggestions, and always tries hard to improve and surpass customer's expectation in all aspects, not only in designs and manufacturing, but also in sales, marketing, logistics, and after services. Cooltron believes only satisfied customers will guarantee long term business and relationship.

Company Overview

Since the incept in California USA in 1999, Cooltron has been designing, manufacturing, and supplying to the worldwide thermal management markets broad lines of fans, blowers, heat sinks, parts and accessories for over 19 years. With devotion to technologies innovation, dedication to customization, strives to best product cost/performance and customer satisfaction, Cooltron has won reputation from global customers in a great variety of application markets such as Telecom & Networking, Power Supply, Industrial, Medical.

Integral & Complete Total Thermal Solutions

Cooltron provides more integral and complete Total Thermal Solutions, starting from Initial Design Cycle, CFD Modeling & Thermal Simulation, Prototype, Pilot Run, Mass Production, Logistic, till After Services for customers' one-stop shopping conveniences.

Beyond Designs & Manufacturing

In addition to designs and manufacturing, Cooltron also consults its customers with competitive sales & marketing strategies to work out the most optimum thermal product that will meet customers' specification requirements and t the market positioning as well.

Mission Statement

Cooltron is committed to product excellence and has been continuously striving for innovation and incorporation of new Thermal Management technologies, adoption of new production techniques and materials that help Cooltron make better thermal performance, more energy ecient and longer life time fans, blowers, and heat sinks.

FAN PART NUMBER SYSTEM

FANS AND BLOWERS

FD 2510 B 05 W 3 C-11-2N X C 1

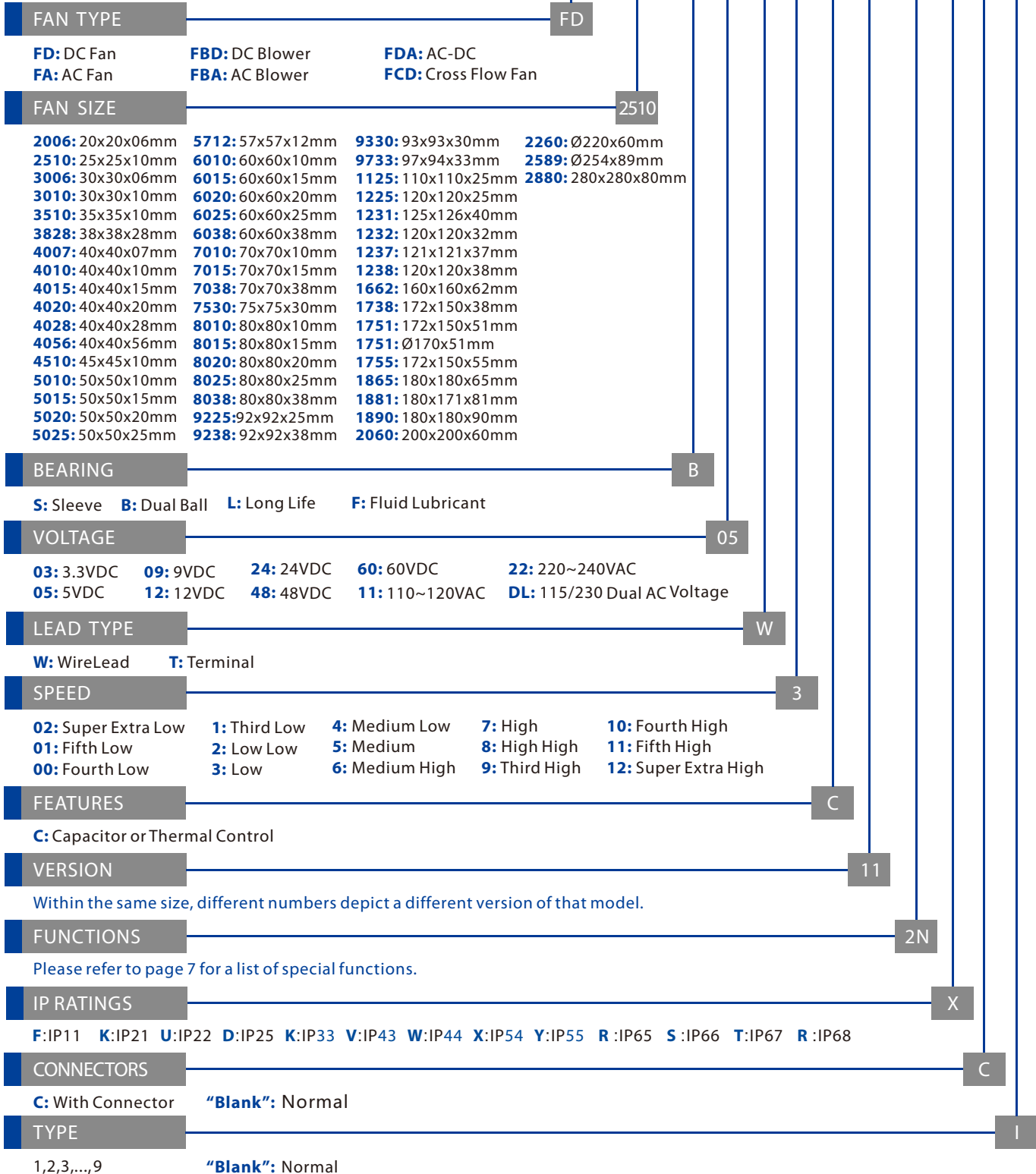







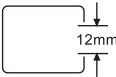
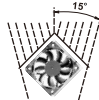

SPECIAL OPTIONS

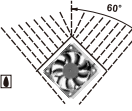
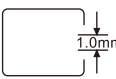
IP

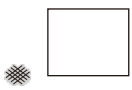
INGRESS PROTECTION RATING

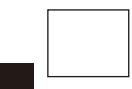
IP (Ingress Protection) Ratings are developed by the European Committee for Electro Technical Standardization (CENELEC) to specify the environmental protection an enclosure provides.

First Digit	Protection From Solid Objects	Second Digit	Protection From Liquid
2	 Touching by finger or 12mm dia. objects	2	 Showering at 15° No harmful ingress
3	 Touching by tools or wire 2.5mm dia. or 2.5mm dia. objects	3	 Showering at 60° No harmful ingress
4	 Touching by tools or wire 1.0mm dia. or 1.0mm dia. objects	4	 Splashing from any directions No harmful ingress
5	 Total touch protection or no harmful ingress of dust	5	 Water jets from any directions No harmful ingress
6	 Total touch protection or no ingress of dust	6	 Large volumes of water No ingress

SF

SPECIAL FUNCTIONS (SUFFIX CODES)

- | | |
|--|---|
| 2N: Standard Leads(2 wires) | 3P: Thermistor + Alarm High-Low + Auto Restart |
| 2R: Auto Restart IC (2 wires) | 3Q: Thermistor + F/G + Auto Restart |
| 2K: Thermistor + Auto Restart (2 wires) | 3S: PWM + Auto Restart |
| 3H: Alarm High + Auto Restart (3 wires) | 3T: PWM + Thermistor + Auto Restart |
| 3L: Alarm Low + Auto Restart (3 wires) | 4T: Thermistor + F/G + Auto Restart |
| 3C: Alarm High-Low + Auto Restart (3 wires) | 4M: Thermistor + Alarm High + Auto Restart |
| 3R: F/G + Auto Restart (3 wires) | 4P: Thermistor + Alarm Low + Auto Restart |
| 3F: F/G (3 wires) | 4K: PWM + Alarm High + Auto Restart |
| 3J: Thermistor +Auto Restart (3 wires) | 4F: PWM + Alarm Low + Auto Restart |
| 3K: Thermistor (3 wires) | 4G: PWM + Alarm High-Low+ Auto Restart |
| 3U: Thermistor + Alarm High + Auto Restart | 4J: PWM + F/G + Auto Restart |
| 3M: Thermistor + Alarm Low + Auto Restart | |

F/G = Frequency Generator, equivalent to Speed Sensor/Tachometer

DC AXIAL FAN 40x40x28mm

(High Performance Fan Series)

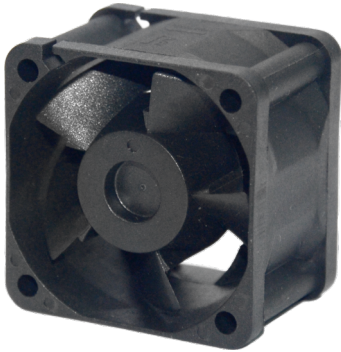

Housing/Blade: Thermoplastic PBT, UL 94V-0
 Insulation Resistance: 10MΩ, 500VDC/min between bare wire and frame
 Dielectric Strength: 5mA max. 500VAC/min between bare wire and frame
 Operation Temperature: -10°C~70°C(Humidity 15%-65%RH)
 Storage Temperature: -20°C~85°C(Humidity 15%-65%RH)
 Lead Wire: UL Type #26 AWG
 Weight: 43 g Packing: 400PCS/CTN



- High Airflow
- Extremely High Static Pressure

Model Number		Voltage (VDC)	Op.Voltage (VDC)	AirFlow (CFM)	StaticPres. (mm-H ₂ O)	Noise (dBA)	Speed (RPM)	Current (mA)	Power (W)	Available Bearing	Curves
FD4028B12W1-88	★▲	12	4.0~13.8	13.00	8.5	44.30	8,000	320	3.84	B	①
FD4028B12W3-88	★▲	12	4.0~13.8	18.60	13.2	46.20	10,000	350	4.20	B	②
FD4028B12W5-88	★▲	12	4.0~13.8	21.40	18.3	49.70	12,000	550	6.60	B	③
FD4028B12W9-88	★▲	12	6.0~13.8	24.40	25.3	53.00	14,000	630	7.56	B	④
FD4028B12W10-88	★▲	12	6.0~13.8	26.10	28.8	54.60	15,000	650	7.80	B	⑤
FD4028B12W11-88	★▲	12	6.0~13.8	28.00	32.7	56.80	16,000	850	10.20	B	⑥
FD4028B12W13-88	★▲	12	6.0~12.8	31.90	37.2	58.30	18,000	2200	26.40	B	⑦
FD4028B12W14-88	★▲	12	6.0~12.8	35.30	45.1	60.40	20,000	2400	28.80	B	⑧

- If model depicts "★", auto restart protection function built in.
- If model depicts "▲", polarity protection function built in.

Specifications are subject to change without notice

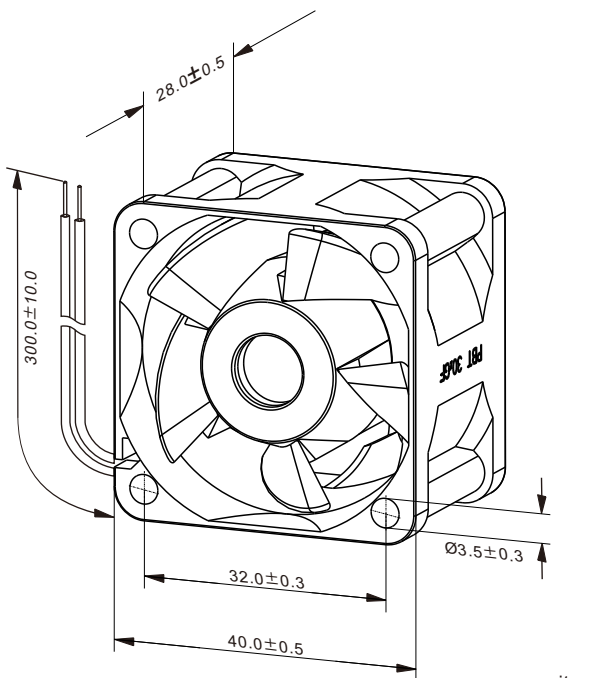

unit: mm

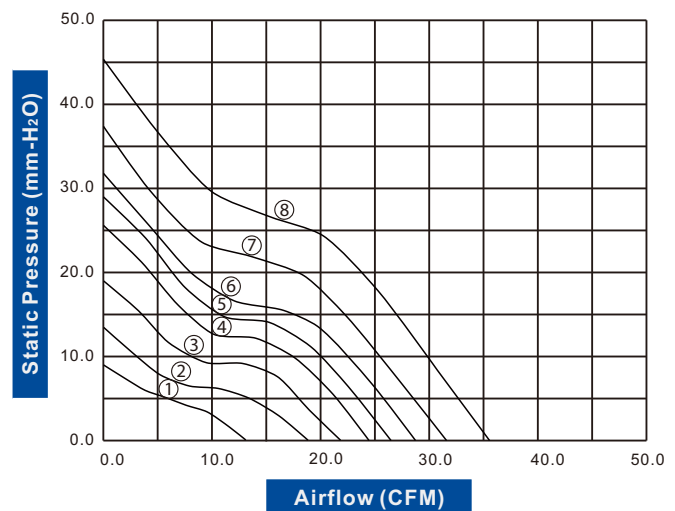

DC AXIAL FAN 40x40x56mm

(High Performance Fan Series)

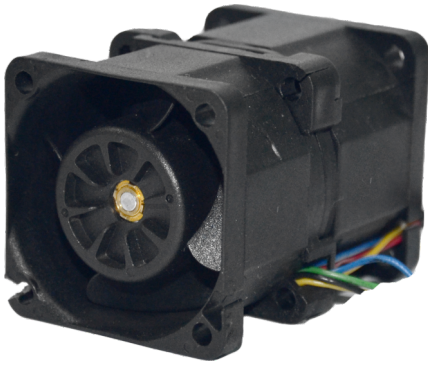

Housing/Blade: Thermoplastic PBT, UL 94V-0
 Insulation Resistance: 10MΩ, 500VDC/min between bare wire and frame
 Dielectric Strength: 5mA max. 500VAC/min between bare wire and frame
 Operation Temperature: -10°C~70°C(Humidity 15%-65%RH)
 Storage Temperature: -20°C~85°C(Humidity 15%-65%RH)
 Lead Wire: UL Type #26 AWG
 Weight: 88.5g Packing: 200PCS/CTN

Model Number	Voltage (VDC)	Op.Voltage (VDC)	AirFlow (CFM)	StaticPres. (mm-H ₂ O)	Noise (dBA)	Speed (RPM)	Current (mA)	Power (W)	Available Bearing	Curves
FD4056B12W3-88H ★▲	12	6.0~13.8	38.70	94.70	73.50	18,000/17,000	2600	31.20	B	①
FD4056B12W5-88H ★▲	12	6.0~13.8	40.70	106.50	74.50	19,000/18,000	2800	33.60	B	②
FD4056B12W7-88H ★▲	12	6.0~13.8	42.60	117.90	75.50	20,000/19,000	3000	36.00	B	③

- If model depicts "★", auto restart protection function built in.
- If model depicts "▲", polarity protection function built in.

Specifications are subject to change without notice

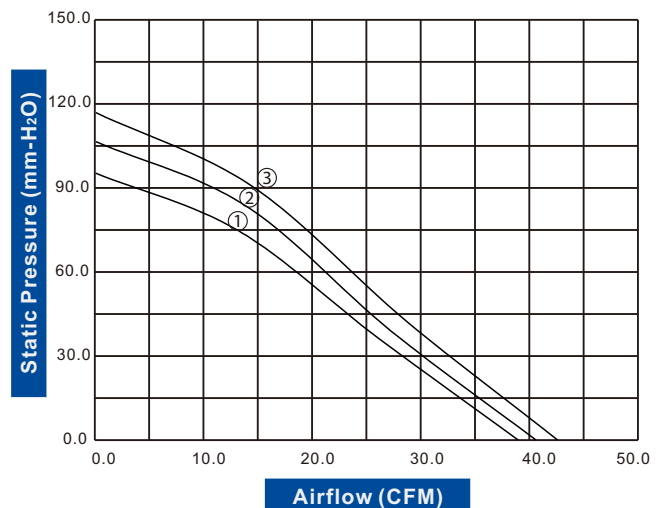
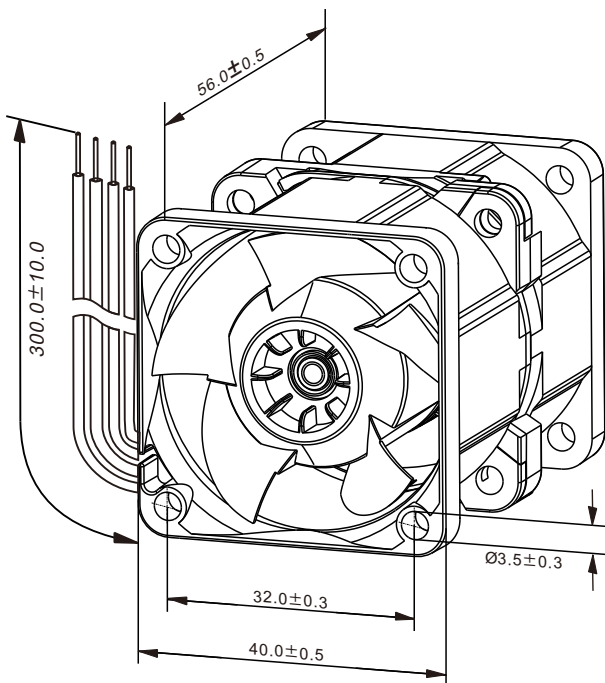

DC AXIAL FAN 60x60x38mm

(High Performance Fan Series)



Housing/Blade: Thermoplastic PBT, UL 94V-0

Insulation Resistance: 10MΩ, 500VDC/min between bare wire and frame

Dielectric Strength: 5mA max. 500VAC/min between bare wire and frame

Operation Temperature: -10°C~70°C(Humidity 5%-90%RH)

Storage Temperature: -40°C~80°C(Humidity 5%-95%RH)

Lead Wire: UL Type #24 AWG

Weight: 145 g Packing: 100PCS/CTN

- High Airflow
- Extremely High Static Pressure

Model Number	Voltage (VDC)	Op.Voltage (VDC)	AirFlow (CFM)	StaticPres. (mm-H ₂ O)	Noise (dBA)	Speed (RPM)	Current (mA)	Power (W)	Available Bearing	Curves
FD6038B12W3-87H ★▲	12	6.0~13.2	26.10	9.38	49.20	6,000	190	2.28	B	①
FD6038B12W5-87H ★▲	12	6.0~13.2	41.60	21.92	51.80	9,000	580	6.96	B	②
FD6038B12W7-87H ★▲	12	6.0~13.2	55.20	38.03	58.00	12,000	1090	13.08	B	③
FD6038B12W9-87H ★▲	12	6.0~13.2	69.10	58.92	62.80	15,000	2070	24.84	B	④
FD6038B12W11-87H ★▲	12	6.0~13.2	85.85	80.05	65.55	17,000	3270	39.24	B	⑤
FD6038B24W3-87H ★▲	24	14.0~26.4	26.10	9.38	49.20	6,000	130	3.12	B	①
FD6038B24W5-87H ★▲	24	14.0~26.4	41.60	21.92	51.80	9,000	260	6.24	B	②
FD6038B24W7-87H ★▲	24	14.0~26.4	55.20	38.03	58.00	12,000	590	14.16	B	③
FD6038B24W9-87H ★▲	24	14.0~26.4	69.10	58.92	62.80	15,000	1150	27.60	B	④
FD6038B24W11-87H ★▲	24	14.0~26.4	85.85	80.05	65.55	17,000	1800	43.20	B	⑤
FD6038B48W3-87H ★▲	48	24.0~52.8	26.10	9.38	49.20	6,000	80	3.84	B	①
FD6038B48W5-87H ★▲	48	24.0~52.8	41.60	21.92	51.80	9,000	150	7.20	B	②
FD6038B48W7-87H ★▲	48	24.0~52.8	55.20	38.03	58.00	12,000	300	14.40	B	③
FD6038B48W9-87H ★▲	48	24.0~52.8	69.10	58.92	62.80	15,000	540	25.92	B	④
FD6038B48W11-87H ★▲	48	24.0~52.8	85.85	80.05	65.55	17,000	820	39.36	B	⑤

- If model depicts "★", auto restart protection function built in.
- If model depicts "▲", polarity protection function built in.

Specifications are subject to change without notice

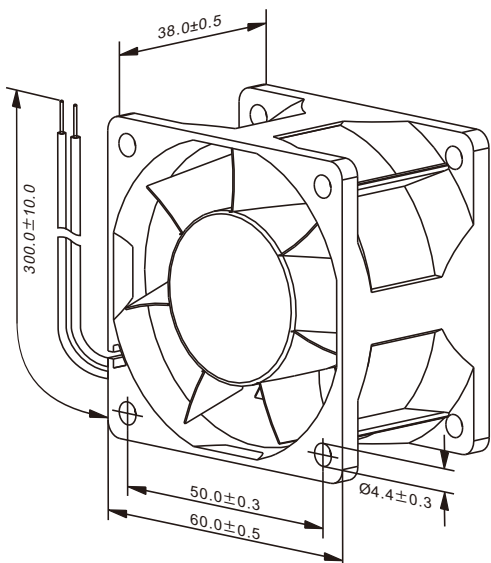

unit: mm

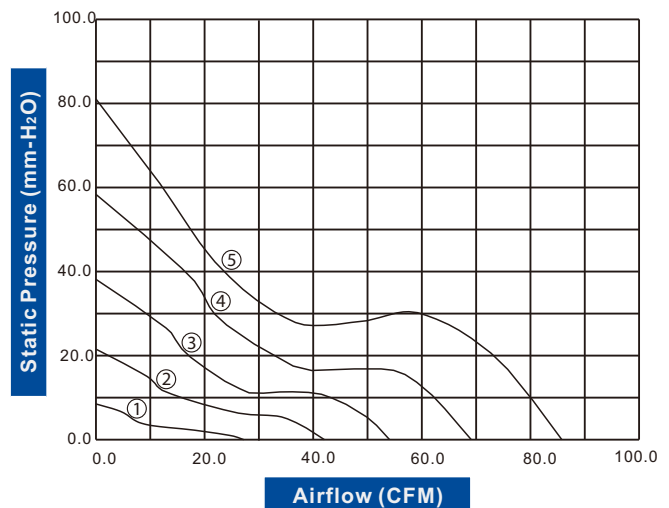

DC AXIAL FAN 80x80x38mm

(High Performance Fan Series)



Housing/Blade: Thermoplastic PBT, UL 94V-0
 Insulation Resistance: 10MΩ, 500VDC/min between bare wire and frame
 Dielectric Strength: 5mA max. 500VAC/min between bare wire and frame
 Operation Temperature: -10°C~70°C(Humidity 5%-90%RH)
 Storage Temperature: -40°C~80°C(Humidity 5%-95%RH)
 Lead Wire: UL Type #24 AWG
 Weight: 210 g Packing: 60PCS/CTN

- High Airflow
- Extremely High Static Pressure

Model Number	Voltage (VDC)	Op.Voltage (VDC)	Air Flow (CFM)	Static Pres. (mm-H ₂ O)	Noise (dBA)	Speed (RPM)	Current (mA)	Power (W)	Available Bearing	Curves	
FD8038B12W3-87A	★▲	12	7.0~13.2	59.10	10.60	44.30	4,200	400	4.80	B	①
FD8038B12W5-87A	★▲	12	7.0~13.2	80.00	19.60	52.20	5,600	760	9.12	B	②
FD8038B12W7-87A	★▲	12	7.0~13.2	86.10	22.90	55.20	6,100	1,000	12.00	B	③
FD8038B12W9-87A	★▲	12	7.0~13.2	107.10	35.10	61.10	7,500	1,500	18.00	B	④
FD8038B12W11-87A	★▲	12	7.0~13.2	132.00	51.60	65.00	9,000	2,700	32.40	B	⑤
FD8038B24W3-87A	★▲	24	14.0~26.4	59.10	10.60	44.30	4,200	250	6.00	B	①
FD8038B24W5-87A	★▲	24	14.0~26.4	80.00	19.60	52.20	5,600	350	8.40	B	②
FD8038B24W7-87A	★▲	24	14.0~26.4	86.10	22.90	55.20	6,100	450	10.80	B	③
FD8038B24W9-87A	★▲	24	14.0~26.4	107.10	35.10	61.10	7,500	820	19.68	B	④
FD8038B24W11-87A	★▲	24	14.0~26.4	132.00	51.60	65.00	9,000	1,400	33.60	B	⑤
FD8038B48W3-87A	★▲※	48	28.0~56.0	59.10	10.60	44.30	4,200	230	11.04	B	①
FD8038B48W5-87A	★▲※	48	28.0~56.0	80.00	19.60	52.20	5,600	330	15.84	B	②
FD8038B48W7-87A	★▲※	48	28.0~56.0	86.10	22.90	55.20	6,100	510	24.48	B	③
FD8038B48W9-87A	★▲※	48	28.0~56.0	107.10	35.10	61.10	7,500	580	27.84	B	④
FD8038B48W11-87A	★▲※	48	28.0~56.0	132.00	51.60	65.00	9,000	900	43.20	B	⑤

- If model depicts "★", auto restart protection function built in.
- If model depicts "▲", polarity protection function built in.
- If model depicts "※", UL approvals can be implemented upon request.

Specifications are subject to change without notice

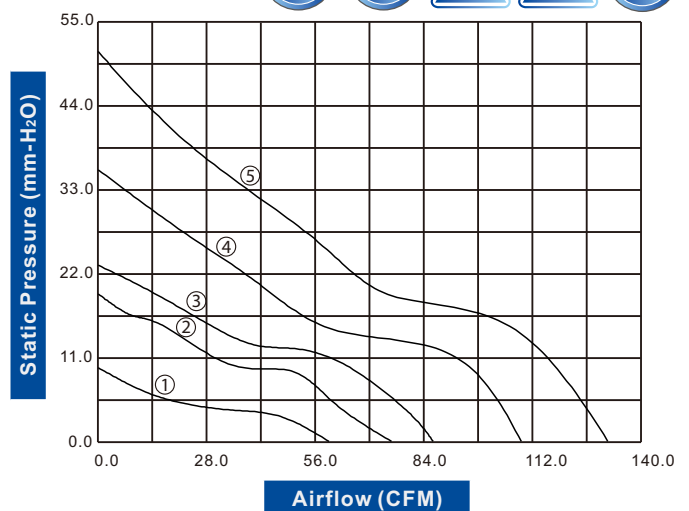
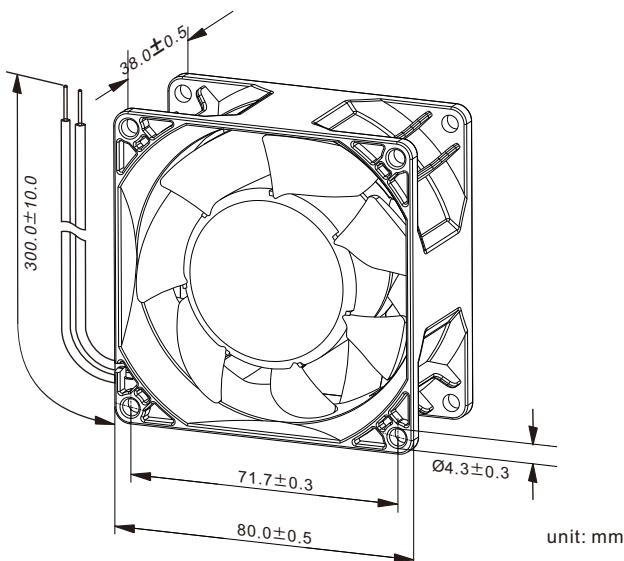

DC AXIAL FAN 80x80x38mm

(High Performance Fan Series)



Housing/Blade: Thermoplastic PBT, UL 94V-0
 Insulation Resistance: 10MΩ, 500VDC/min between bare wire and frame
 Dielectric Strength: 5mA max. 500VAC/min between bare wire and frame
 Operation Temperature: -10°C~70°C(Humidity 15%-65%RH)
 Storage Temperature: -20°C~85°C(Humidity 15%-65%RH)
 Lead Wire: UL Type #24 AWG
 Weight: 177 g Packing: 60PCS/CTN

- High Airflow
- Extremely High Static Pressure

Model Number	Voltage (VDC)	Op.Voltage (VDC)	AirFlow (CFM)	StaticPres. (mm-H ₂ O)	Noise (dBA)	Speed (RPM)	Current (mA)	Power (W)	Available Bearing	Curves
FD8038B12W3-88H ★▲	12	6.5~13.8	64.10	13.20	50.50	5,000	700	8.40	B	①
FD8038B12W5-88H ★▲	12	6.0~13.8	84.20	22.50	57.50	6,500	1,500	18.00	B	②
FD8038B12W7-88H ★▲	12	6.0~13.8	100.60	35.50	62.80	8,000	2,800	33.60	B	③
FD8038B24W3-88H ★▲	24	15.0~30.0	64.10	13.20	50.50	5,000	400	9.60	B	①
FD8038B24W5-88H ★▲	24	15.0~30.0	84.20	22.50	57.50	6,500	700	16.80	B	②
FD8038B24W7-88H ★▲	24	15.0~30.0	100.60	35.50	62.80	8,000	1,600	38.40	B	③
FD8038B48W3-88H ★▲	48	25.0~60.0	64.10	13.20	50.50	5,000	300	14.40	B	①
FD8038B48W5-88H ★▲	48	25.0~60.0	84.20	22.50	57.50	6,500	400	19.20	B	②
FD8038B48W7-88H ★▲	48	25.0~60.0	100.60	35.50	62.80	8,000	1,000	48.00	B	③

- If model depicts "★", auto restart protection function built in.
- If model depicts "▲", polarity protection function built in.

Specifications are subject to change without notice

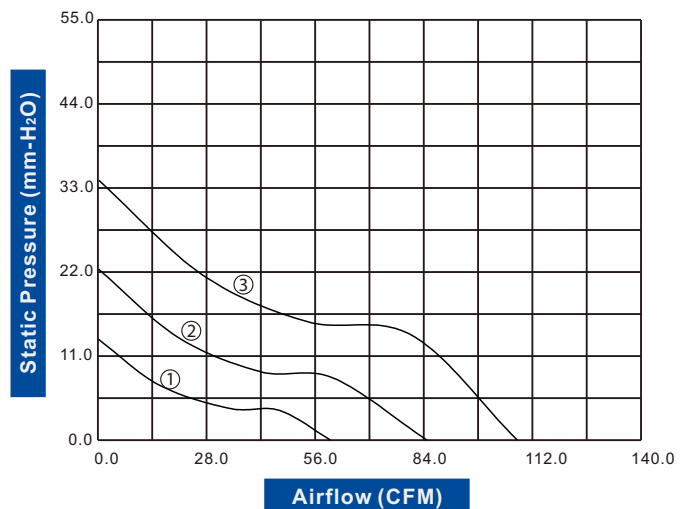
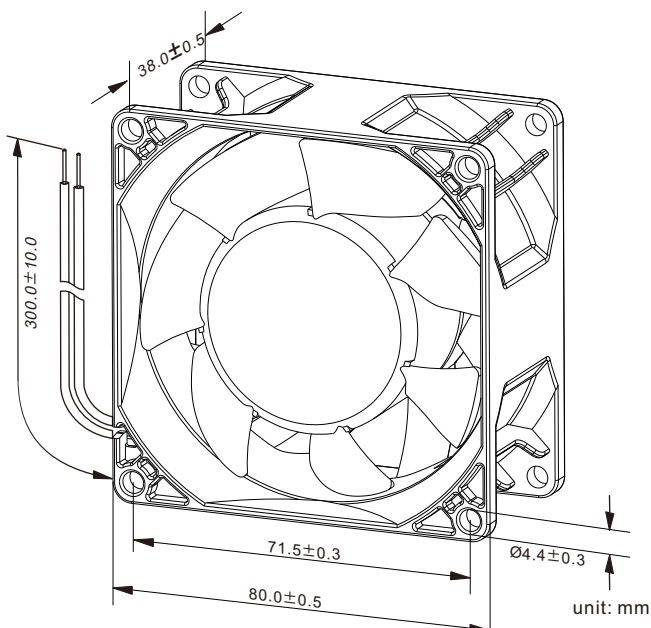

DC AXIAL FAN 92x92x38mm

(High Performance Fan Series)



Housing/Blade: Thermoplastic PBT, UL 94V-0
 Insulation Resistance: 10M Ω , 500VDC/min between bare wire and frame
 Dielectric Strength: 5mA max. 500VAC/min between bare wire and frame
 Operation Temperature: -10°C~70°C(Humidity 5%-90%RH)
 Storage Temperature: -40°C~80°C(Humidity 5%-95%RH)
 Lead Wire: UL Type #24 AWG
 Weight: 200 g Packing: 60PCS/CTN



- High Airflow
- Extremely High Static Pressure

Model Number		Voltage (VDC)	Op.Voltage (VDC)	AirFlow (CFM)	StaticPres. (mm-H ₂ O)	Noise (dBA)	Speed (RPM)	Current (mA)	Power (W)	Available Bearing	Curves
FD9238B12W3-87	★▲	12	7.0~13.2	98.60	18.00	51.20	4,300	500	6.00	B	①
FD9238B12W5-87	★▲	12	7.0~13.2	110.80	22.20	57.10	5,000	900	10.80	B	②
FD9238B12W7-87	★▲	12	7.0~13.2	125.30	28.90	63.00	6,000	1,200	14.40	B	③
FD9238B12W9-87	★▲	12	7.0~13.2	147.80	37.60	66.00	7,000	2,500	30.00	B	④
FD9238B12W11-87	★▲	12	7.0~13.2	158.30	43.20	67.50	7,500	2,710	32.52	B	⑤
FD9238B24W3-87	★▲	24	14.0~26.4	98.60	18.00	51.20	4,300	350	8.40	B	①
FD9238B24W5-87	★▲	24	14.0~26.4	110.80	22.20	57.10	5,000	450	10.80	B	②
FD9238B24W7-87	★▲	24	14.0~26.4	125.30	28.90	63.00	6,000	760	18.24	B	③
FD9238B24W9-87	★▲	24	14.0~26.4	147.80	37.60	66.00	7,000	1,100	26.40	B	④
FD9238B24W11-87	★▲	24	14.0~26.4	158.30	43.20	67.50	7,500	1,650	39.60	B	⑤
FD9238B48W3-87	★▲	48	28.0~56.0	98.60	18.00	51.20	4,300	240	11.52	B	①
FD9238B48W5-87	★▲	48	28.0~56.0	110.80	22.20	57.10	5,000	280	13.44	B	②
FD9238B48W7-87	★▲	48	28.0~56.0	125.30	28.90	63.00	6,000	410	19.68	B	③
FD9238B48W9-87	★▲	48	28.0~56.0	147.80	37.60	66.00	7,000	600	28.80	B	④
FD9238B48W11-87	★▲	48	28.0~56.0	158.30	43.20	67.50	7,500	900	43.20	B	⑤

- If model depicts "★", auto restart protection function built in.
- If model depicts "▲", polarity protection function built in.

Specifications are subject to change without notice

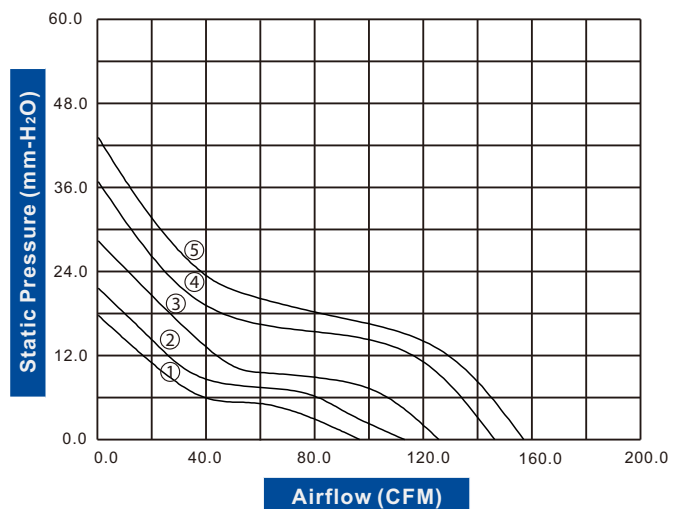
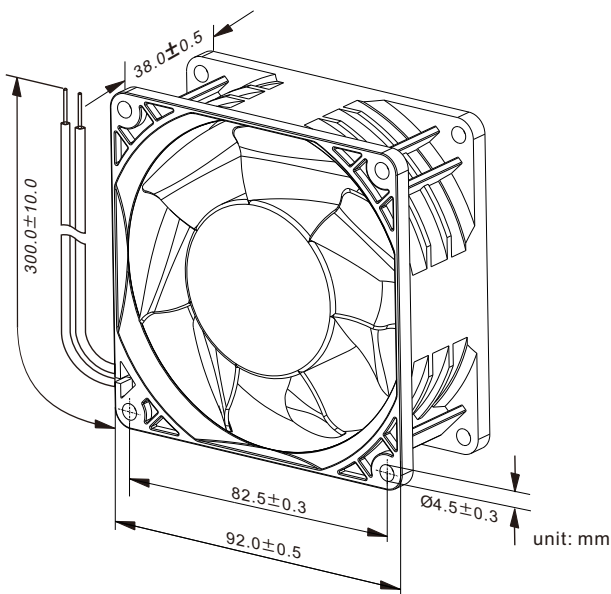

DC AXIAL FAN 120x120x38mm

(High Performance Fan Series)



Housing/Blade: Thermoplastic PBT, UL 94V-0
 Insulation Resistance: 10M Ω , 500VDC/min between bare wire and frame
 Dielectric Strength: 5mA max. 500VAC/min between bare wire and frame
 Operation Temperature: -10°C~70°C(Humidity 5%-90%RH)
 Storage Temperature: -40°C~80°C(Humidity 5%-95%RH)
 Lead Wire: UL Type #22 AWG
 Weight: 450 g Packing: 40PCS/CTN

- High Airflow
- Extremely High Static Pressure

Model Number	Voltage (VDC)	Op.Voltage (VDC)	AirFlow (CFM)	StaticPres. (mm-H ₂ O)	Noise (dBA)	Speed (RPM)	Current (mA)	Power (W)	Available Bearing	Curves
FD1238B12W3-87C ★▲	12	7.0~13.2	174.00	18.00	59.10	4,000	2,000	24.00	B	①
FD1238B12W5-87C ★▲	12	7.0~13.2	209.40	26.60	64.00	4,800	2,500	30.00	B	②
FD1238B12W7-87C ★▲	12	7.0~13.2	238.20	34.80	68.00	5,500	3,880	46.56	B	③
FD1238B24W3-87C ★▲	24	14.0~26.4	174.00	18.00	59.10	4,000	1,300	31.20	B	①
FD1238B24W5-87C ★▲	24	14.0~26.4	209.40	26.60	64.00	4,800	1,800	43.20	B	②
FD1238B24W7-87C ★▲	24	14.0~26.4	238.20	34.80	68.00	5,500	2,500	60.00	B	③
FD1238B24W9-87C ★▲	24	14.0~26.4	269.80	44.90	70.90	6,200	2,720	65.28	B	④
FD1238B48W3-87C ★▲	48	28.0~56.0	174.00	18.00	59.10	4,000	600	28.80	B	①
FD1238B48W5-87C ★▲	48	28.0~56.0	209.40	26.60	64.00	4,800	900	43.20	B	②
FD1238B48W7-87C ★▲	48	28.0~56.0	238.20	34.80	68.00	5,500	1,200	57.60	B	③
FD1238B48W9-87C ★▲	48	28.0~56.0	269.80	44.90	70.90	6,200	1,300	62.40	B	④

- If model depicts "★", auto restart protection function built in.
- If model depicts "▲", polarity protection function built in.

Specifications are subject to change without notice

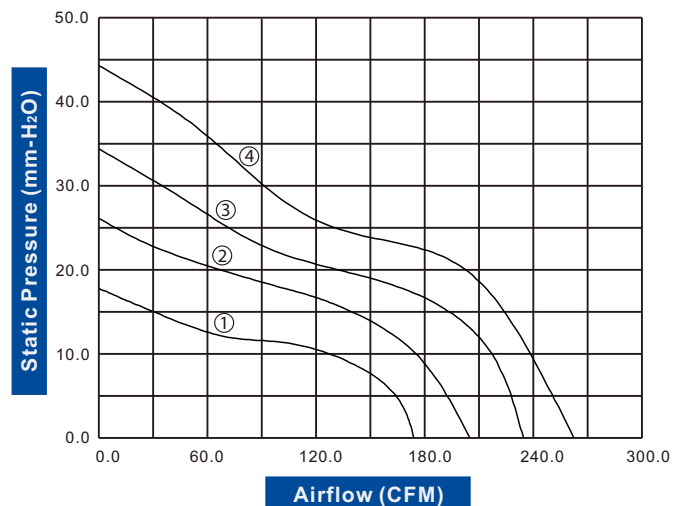
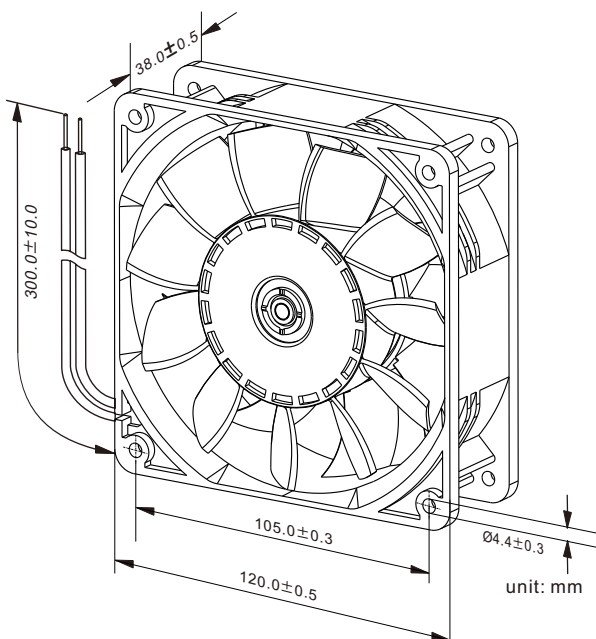

DC AXIAL FAN 120x120x38mm

(High Performance Fan Series)



Housing/Blade: Thermoplastic PBT, UL 94V-0
 Insulation Resistance: 10M Ω , 500VDC/min between bare wire and frame
 Dielectric Strength: 5mA max. 500VAC/min between bare wire and frame
 Operation Temperature: -10°C~70°C(Humidity 15%-65%RH)
 Storage Temperature: -20°C~85°C(Humidity 15%-65%RH)
 Lead Wire: UL Type #24 AWG
 Weight: 292 g Packing: 40PCS/CTN

- High Airflow
- Extremely High Static Pressure

Model Number		Voltage (VDC)	Op.Voltage (VDC)	AirFlow (CFM)	StaticPres. (mm-H ₂ O)	Noise (dBA)	Speed (RPM)	Current (mA)	Power (W)	Available Bearing	Curves
FD1238B12W3-88	★▲	12	6.0~13.8	196.60	11.80	59.00	3,500	1,900	22.80	B	①
FD1238B12W5-88	★▲	12	6.0~13.8	226.70	13.40	64.60	4,000	2,500	30.00	B	②
FD1238B12W7-88	★▲	12	6.0~13.8	262.30	17.30	66.20	4,500	3,000	36.00	B	③
FD1238B24W3-88	★▲	24	15.0~30.0	196.60	11.80	59.00	3,500	1,200	28.80	B	①
FD1238B24W5-88	★▲	24	15.0~30.0	262.30	17.30	66.20	4,500	1,800	43.20	B	③
FD1238B24W7-88	★▲	24	15.0~30.0	303.10	22.50	69.00	5,500	2,800	67.20	B	④
FD1238B48W3-88	★▲	48	25.0~60.0	196.60	11.80	59.00	3,500	700	33.60	B	①
FD1238B48W5-88	★▲	48	25.0~60.0	262.30	17.30	66.20	4,500	1,000	48.00	B	③
FD1238B48W7-88	★▲	48	25.0~60.0	303.10	22.50	69.00	5,500	1,300	62.40	B	④

- If model depicts "★", auto restart protection function built in.
- If model depicts "▲", polarity protection function built in.

Specifications are subject to change without notice

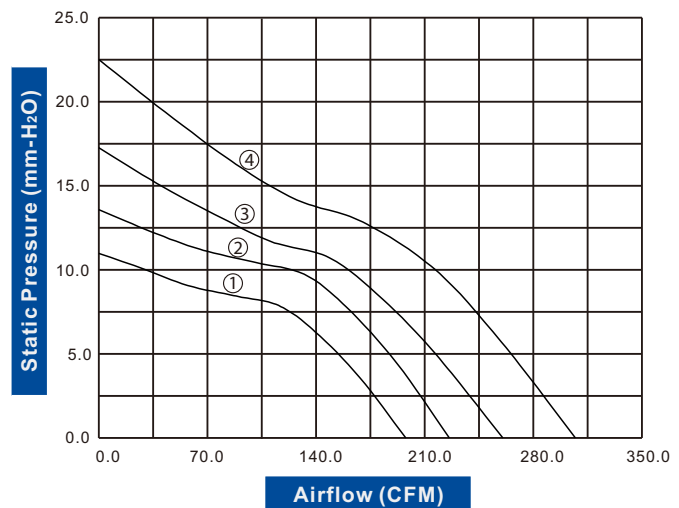
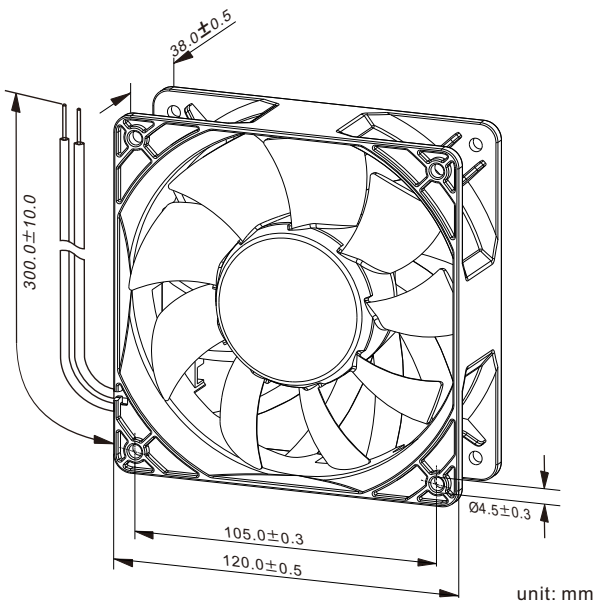



USA

19929 Harrison Ave.
City of Industry, CA 91789
Tel: +1-909-598-6033
Fax: +1-909-598-6043

CHINA

5F Xingyue Building, Shiguan Industrial Park,
Longhua New District, Shenzhen, China.
Tel: +86-755-8209-0805
Fax: +86-755-2904-3077