

5 INSTALLING CORD ASSEMBLY

Insert cord assembly into panel; see Detail "A" and "B" for panel step location

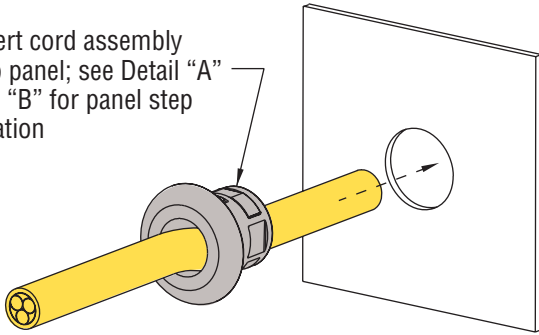

Each panel thickness has $\pm .015''$ (0,4 mm)

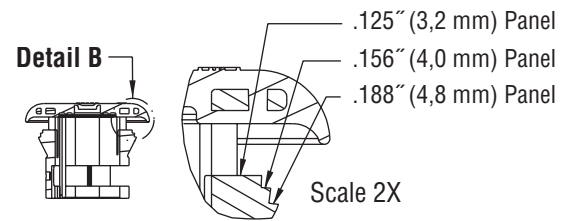
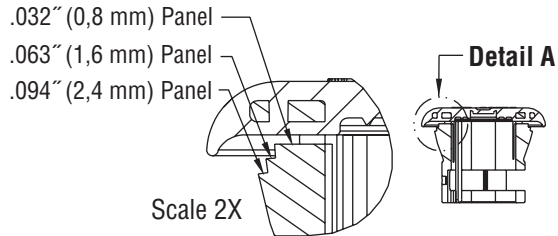

6 SUCCESSFUL INSTALLATION

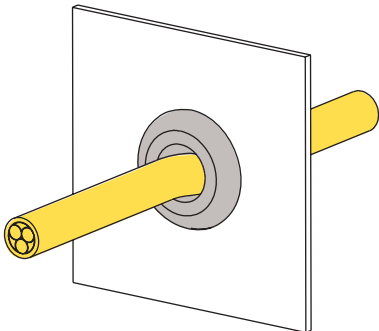

PART NO.	COLOR	DESCRIPTION	WIRE RANGE \emptyset	
			(in.)	(mm)
1063	BLACK	LTBSR 875 - 094 - 330	.280" - .330"	7,1 - 8,4
1064		LTBSR 875 - 188 - 330		
1065		LTBSR 875 - 094 - 440	.330" - .440"	8,4 - 11,2
1066		LTBSR 875 - 188 - 440		
1067	WHITE	LTBSR 875 - 094 - 330	.280" - .330"	7,1 - 8,4
1068		LTBSR 875 - 188 - 330		
1069		LTBSR 875 - 094 - 440	.330" - .440"	8,4 - 11,2
1070		LTBSR 875 - 188 - 440		
1071	LT. GRAY**	LTBSR 875 - 094 - 330	.280" - .330"	7,1 - 8,4
1072		LTBSR 875 - 188 - 330		
1073		LTBSR 875 - 094 - 440	.330" - .440"	8,4 - 11,2
1076		LTBSR 875 - 188 - 440		
0029A	BLACK	LTBSR PLIER ADAPTOR	N/A	
0029	N/A	LTBSR PLIER	N/A	
0029-P		LTBSR PLIER - 10 PK	N/A	

**LT. GRAY is RAL 7035

For a video demonstration of the crimping and panel installation, scan the code below.



These instructions can also be found on-line at www.heyco.com



a PennEngineering® Company

1800 Industrial Way, Toms River, NJ 08755
800.526.4182 • sales@heyco.com

©Copyright, Heyco Products Corp., 2020 Rev. 5/20 Printed in USA

Heyco® Liquid Tight Strain Relief Bushing

Instructions for Assembly and Installation

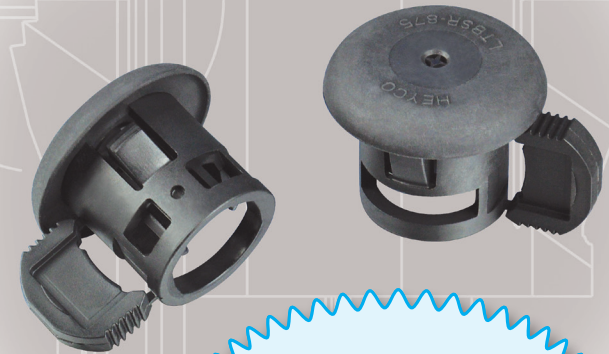

Snap-in, Low Profile Design Allows for Pre-assembled Cables

Patent #10573436



a PennEngineering® Company

INSTALLATION AND CRIMPING OPTIONS

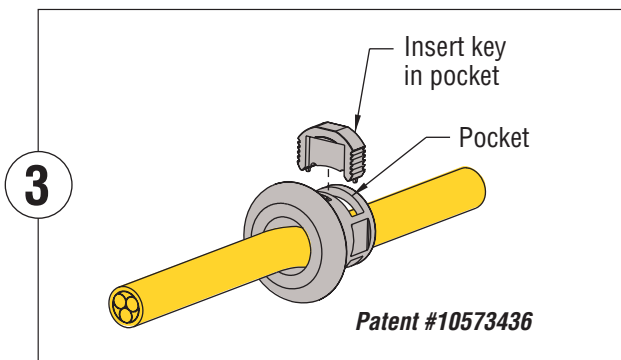
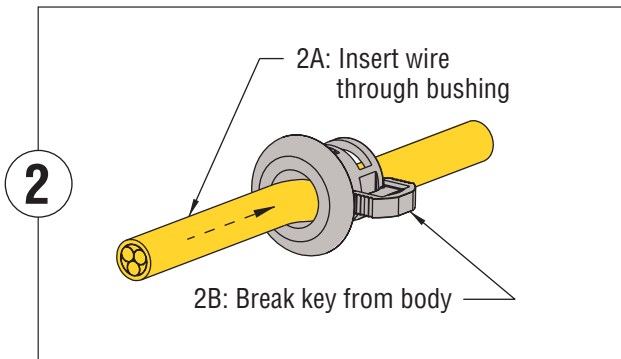
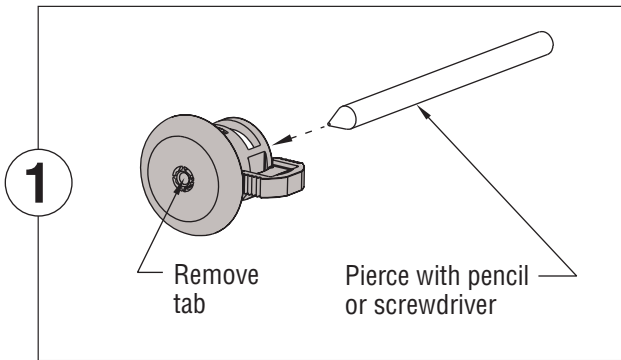

4a CAST PLIER METHOD (Part No. 0029) Nylon Adaptor NOT Required

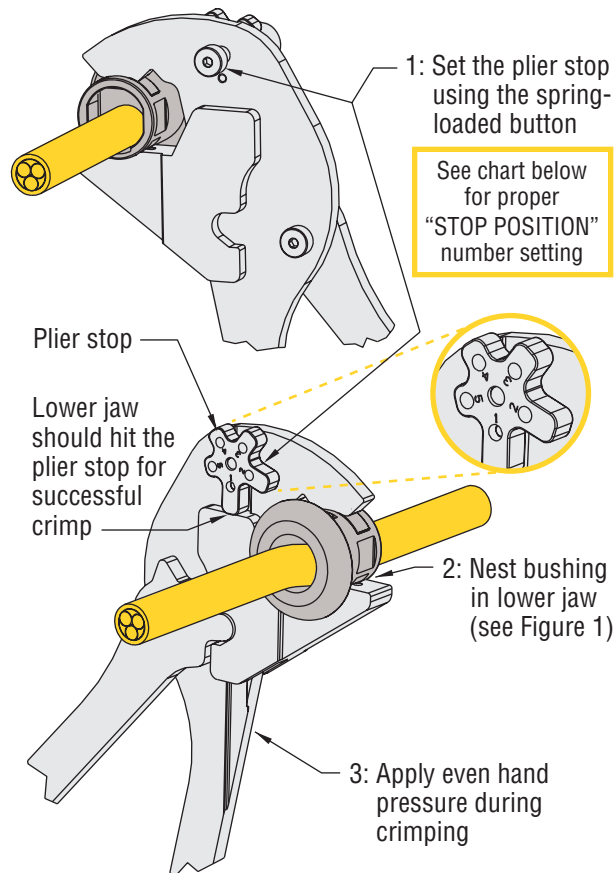
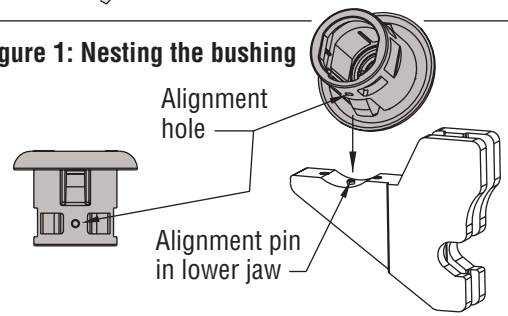

Figure 1: Nesting the bushing



PLIER STOP SPECIFICATIONS

STOP POSITION	(in.)	WIRE RANGE Ø (mm)
1	.440" - .430"	11,2 - 10,9
2	.430" - .390"	10,9 - 9,9
3	.390" - .350"	9,9 - 8,9
4	.350" - .300"	8,9 - 7,6
5	.300" - .280"	7,6 - 7,1

4b ALTERNATE PLIER METHOD REQUIRES Nylon Adaptor (Part No. 0029A / included)

Nylon Adaptor Part No. 0029A (included) is compatible with 10" pliers; either Workpro Item #W031138 or Kobalt Item #64426 (available commercially)

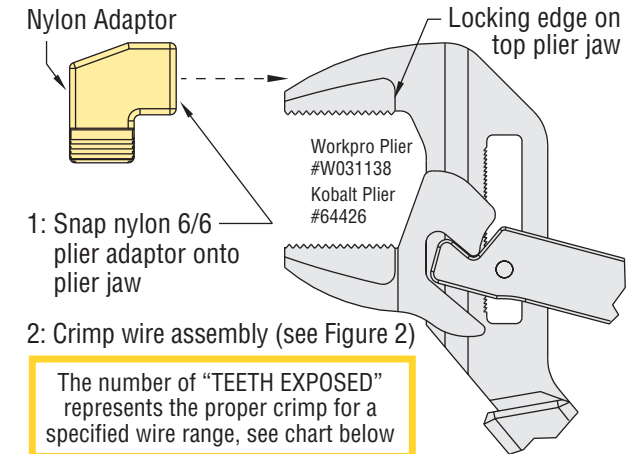

3: To achieve successful crimp height, each time the key clicks into the body, release pressure on the plier handle and re-engage to continue on to the desired locking position

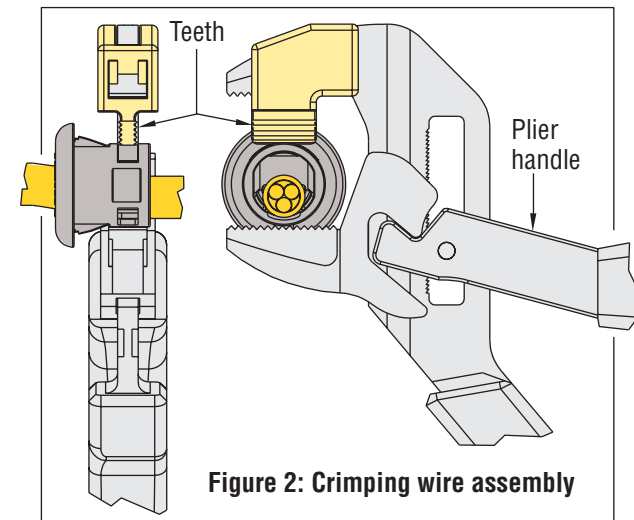

CRIMP SPECIFICATIONS

TEETH EXPOSED	(in.)	WIRE RANGE Ø (mm)
5	.440" - .430"	11,2 - 10,9
4	.430" - .390"	10,9 - 9,9
3	.390" - .350"	9,9 - 8,9
2	.350" - .300"	8,9 - 7,6
1	.300" - .280"	7,6 - 7,1

...Continue to step 4a if using the Cast Plier crimping method, or 4b if using the Alternate Plier method