

**EC Motorized Impeller
Backward Curved
Ø133x61 mm**



Impeller:	Plastic PA6.6(Polyamide Glass-fiber Reinforced)
Motor:	Brushless External Motor
Rotor:	Black Paint
Bearing:	Dual Ball Bearing
Insulation:	Class "A" or "B"
Operating Volt. Range:	95VAC to 138VAC for 115V Type 185VAC to 280VAC for 230V Type
Technical Features:	0-10VDC/PWM Speed Control; Tachometer Output; Locked Rotor Protection; Current Limited; Soft Start.
Operating Temp.:	-20°C to +60°C
Weight:	925 g

Model Number	Voltage (VAC)	Frequency (Hz)	AirFlow (CFM)	AirFlow (m ³ /H)	StaticPres. (mm-H ₂ O)	StaticPres. (inH ₂ O)	Noise (dBA)	Speed (RPM)	Current (mA)	Power (W)	Curves
FEI13361B11W9-57	115	50/60	271.20	460.60	46.00	1.80	69.70	4,600	840	56.00	①
FEI13361B22W9-57	230	50/60	271.20	460.60	46.00	1.80	69.70	4,600	420	56.00	①

Specifications are subject to change without notice

Characteristic Curves:

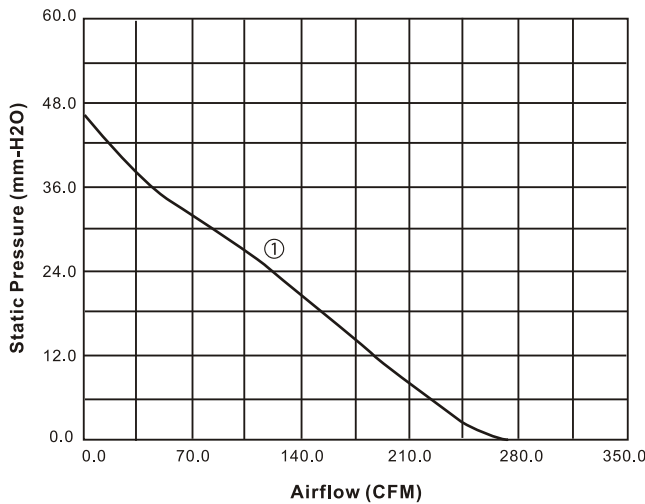

Outline Drawing:

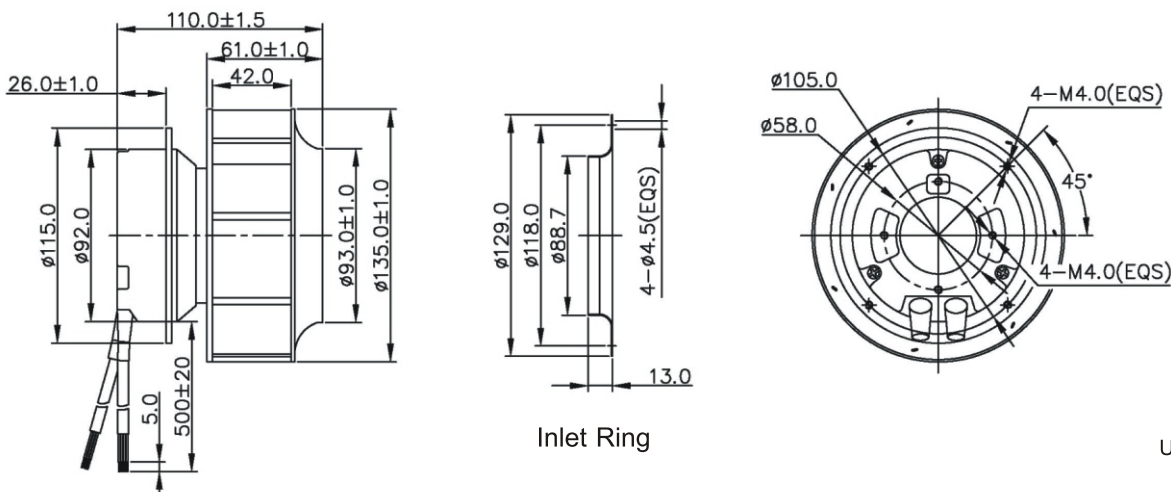

Inlet Ring

Unit:mm

**EC Motorized Impeller
Backward Curved
Ø175x62mm**



Impeller:	Plastic PA6.6(Polyamide Glass-fiber Reinforced)
Motor:	Brushless External Motor
Rotor:	Black Paint
Bearing:	Dual Ball Bearing
Insulation:	Class "A" or "B"
Operating Volt. Range:	95VAC to 138VAC for 115V Type 185VAC to 280VAC for 230V Type
Technical Features:	0-10VDC/PWM Speed Control; Tachometer Output; Locked Rotor Protection; Current Limited; Soft Start.
Operating Temp.:	-20°C to +60°C
Weight:	1200 g

Model Number	Voltage (VAC)	Frequency (Hz)	AirFlow (CFM)	AirFlow (m ³ /H)	StaticPres. (mm-H ₂ O)	StaticPres. (inH ₂ O)	Noise (dBA)	Speed (RPM)	Current (mA)	Power (W)	Curves
FEI17562B11W7-57	115	50/60	429.40	729.50	44.90	1.80	67.70	4,500	1500	110.00	①
FEI17562B22W7-57	230	50/60	429.40	729.50	44.90	1.80	67.70	4,500	750	110.00	①

Specifications are subject to change without notice

Characteristic Curves:

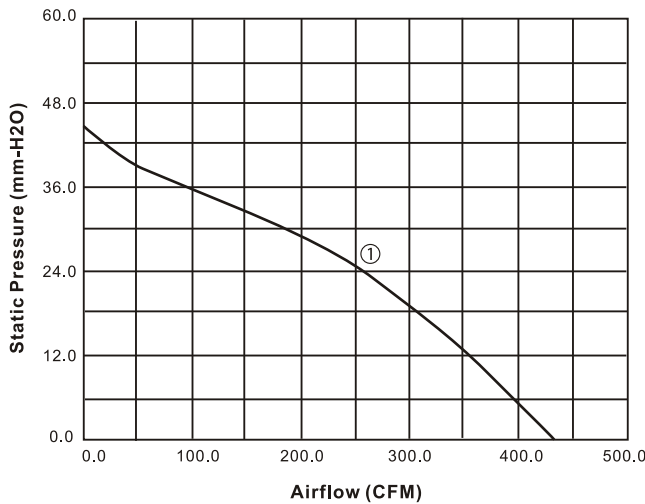

Outline Drawing:

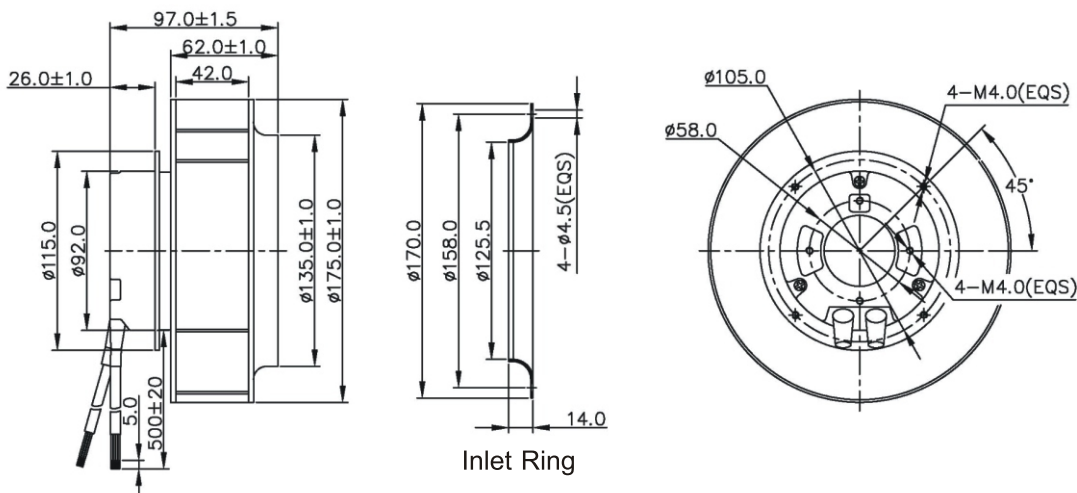

Unit:mm

**EC Motorized Impeller
Backward Curved
Ø190x63mm**



Impeller:	Plastic PA6.6(Polyamide Glass-fiber Reinforced)
Motor:	Brushless External Motor
Rotor:	Black Paint
Bearing:	Dual Ball Bearing
Insulation:	Class "A" or "B"
Operating Volt. Range:	95VAC to 138VAC for 115V Type 185VAC to 280VAC for 230V Type
Technical Features:	0-10VDC/PWM Speed Control; Tachometer Output; Locked Rotor Protection; Current Limited; Soft Start.
Operating Temp.:	-20°C to +60°C
Weight:	1300 g

Model Number	Voltage (VAC)	Frequency (Hz)	AirFlow (CFM)	Air Flow (m ³ /H)	StaticPres. (mm-H ₂ O)	StaticPres. (inH ₂ O)	Noise (dBA)	Speed (RPM)	Current (mA)	Power (W)	Curves
FEI19063B11W7-57	115	50/60	467.10	793.40	78.10	3.10	71.10	3,500	1700	106.00	①
FEI19063B22W7-57	230	50/60	467.10	793.40	78.10	3.10	71.10	3,500	850	106.00	①

Specifications are subject to change without notice

Characteristic Curves:

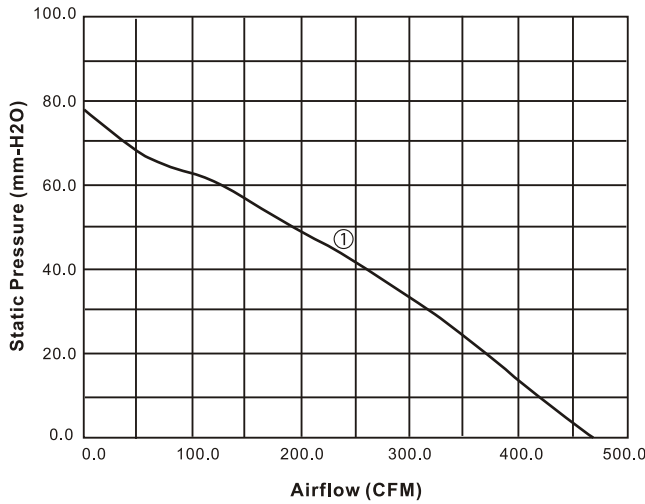

Outline Drawing:

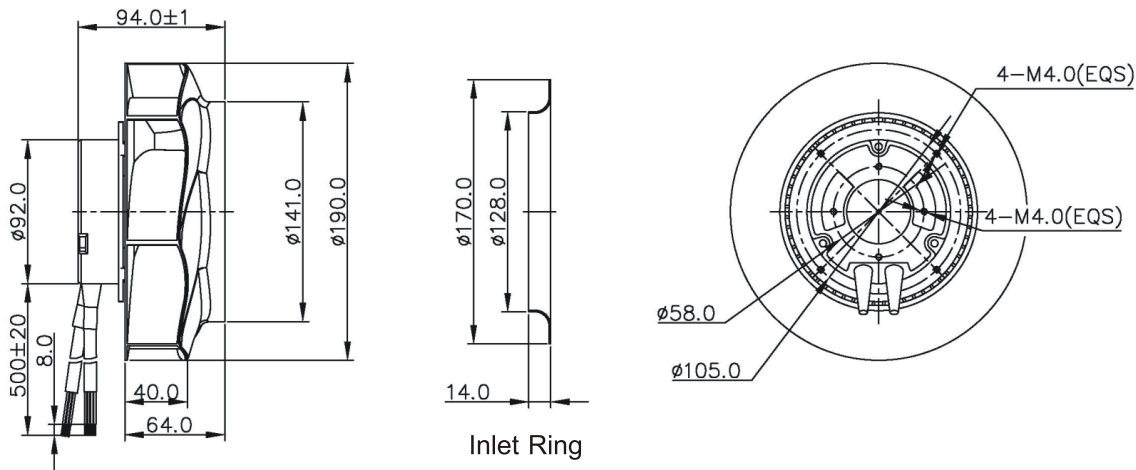

**EC Motorized Impeller
Backward Curved
Ø200x65mm**



Impeller:	Plastic PA6.6(Polyamide Glass-fiber Reinforced)
Motor:	Brushless External Motor
Rotor:	Black Paint
Bearing:	Dual Ball Bearing
Insulation:	Class "A" or "B"
Operating Volt. Range:	95VAC to 138VAC for 115V Type 185VAC to 280VAC for 230V Type
Technical Features:	0-10VDC/PWM Speed Control; Tachometer Output; Locked Rotor Protection; Current Limited; Soft Start.
Operating Temp.:	-20°C to +60°C
Weight:	2250 g

Model Number	Voltage (VAC)	Frequency (Hz)	AirFlow (CFM)	AirFlow (m ³ /H)	StaticPres. (mm-H ₂ O)	StaticPres. (inH ₂ O)	Noise (dBA)	Speed (RPM)	Current (mA)	Power (W)	Curves
FEI20065B11W7-57	115	50/60	485.70	825.20	89.20	3.50	64.70	4,000	3000	219.00	①
FEI20065B22W7-57	230	50/60	485.70	825.20	89.20	3.50	64.70	4,000	1500	219.00	①

Specifications are subject to change without notice

Characteristic Curves:

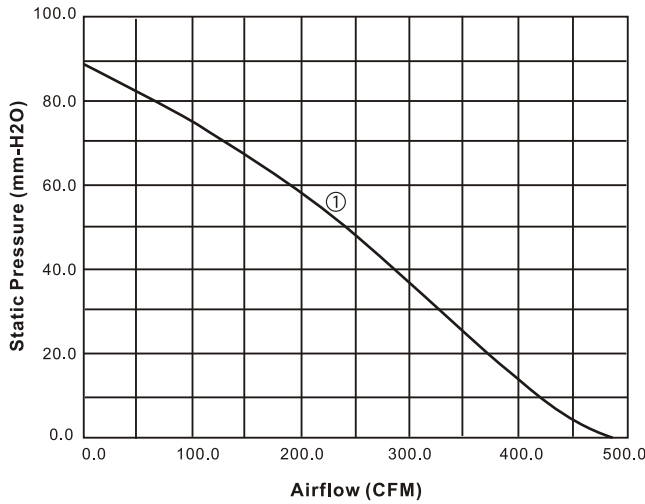

Outline Drawing:

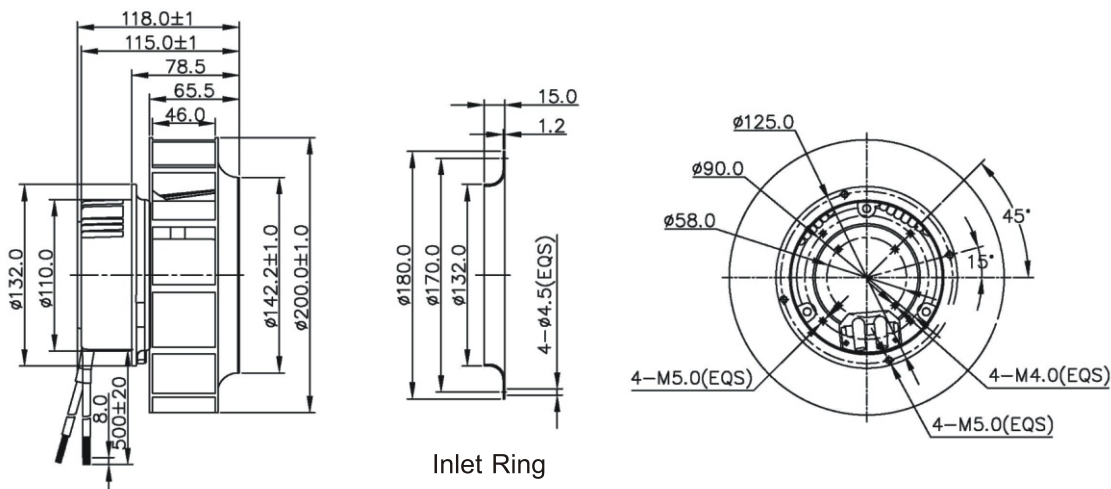

Unit:mm

**EC Motorized Impeller
Backward Curved
Ø220x63mm**



Impeller:	Plastic PA6.6(Polyamide Glass-fiber Reinforced)
Motor:	Brushless External Motor
Rotor:	Black Paint
Bearing:	Dual Ball Bearing
Insulation:	Class "A" or "B"
Operating Volt. Range:	95VAC to 138VAC for 115V Type 185VAC to 280VAC for 230V Type
Technical Features:	0-10VDC/PWM Speed Control; Tachometer Output; Locked Rotor Protection; Current Limited; Soft Start.
Operating Temp.:	-20°C to +60°C
Weight:	1340 g

Model Number	Voltage (VAC)	Frequency (Hz)	AirFlow (CFM)	Air Flow (m ³ /H)	StaticPres. (mm-H ₂ O)	StaticPres. (inH ₂ O)	Noise (dBA)	Speed (RPM)	Current (mA)	Power (W)	Curves
FEI22063B11W7-57	115	50/60	567.00	963.20	40.20	1.60	69.70	3,200	1400	110.00	①
FEI22063B22W7-57	230	50/60	567.00	963.20	40.20	1.60	69.70	3,200	700	110.00	①

Specifications are subject to change without notice

Characteristic Curves:

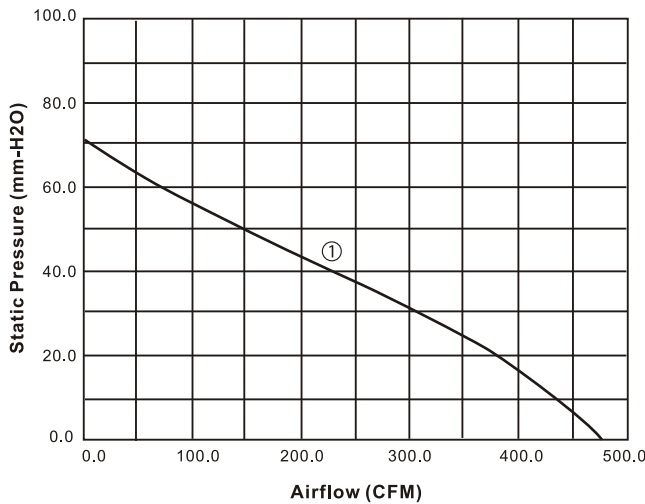

Outline Drawing:

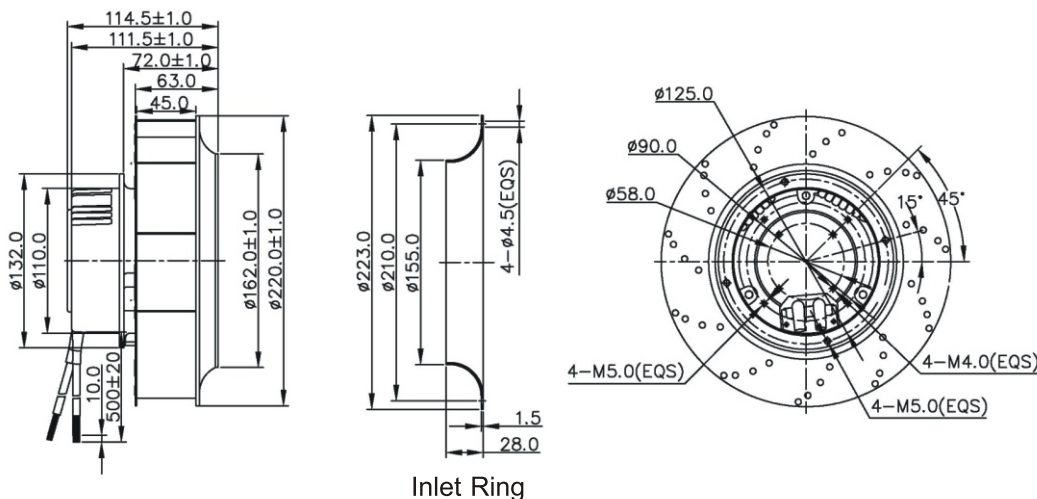

Unit:mm

**EC Motorized Impeller
Backward Curved
Ø225x90mm**



Impeller:	Plastic PA6.6(Polyamide Glass-fiber Reinforced)
Motor:	Brushless External Motor
Rotor:	Black Paint
Bearing:	Dual Ball Bearing
Insulation:	Class "A" or "B"
Operating Volt. Range:	95VAC to 138VAC for 115V Type 185VAC to 280VAC for 230V Type
Technical Features:	0-10VDC/PWM Speed Control; Tachometer Output; Locked Rotor Protection; Current Limited; Soft Start.
Operating Temp.:	-20°C to +60°C
Weight:	1500 g

Model Number	Voltage (VAC)	Frequency (Hz)	AirFlow (CFM)	Air Flow (m ³ /H)	StaticPres. (mm-H ₂ O)	StaticPres. (inH ₂ O)	Noise (dBA)	Speed (RPM)	Current (mA)	Power (W)	Curves
FEI22590B11W7-57	115	50/60	717.00	1218.10	56.30	2.20	68.70	2,500	1600	100.00	①
FEI22590B22W7-57	230	50/60	717.00	1218.10	56.30	2.20	68.70	2,500	800	100.00	①

Specifications are subject to change without notice

Characteristic Curves:

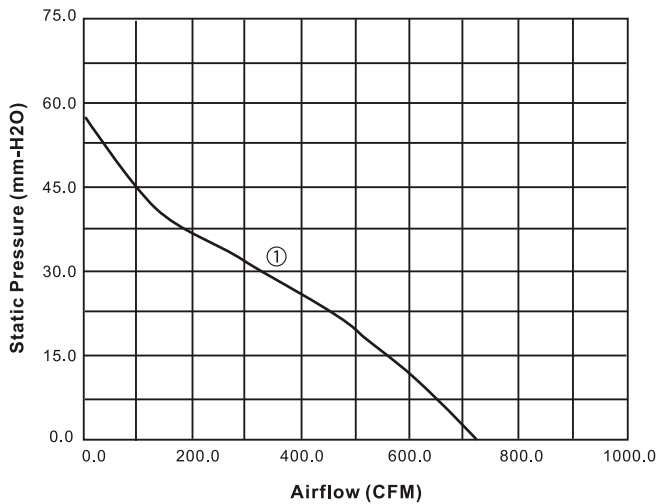

Outline Drawing:

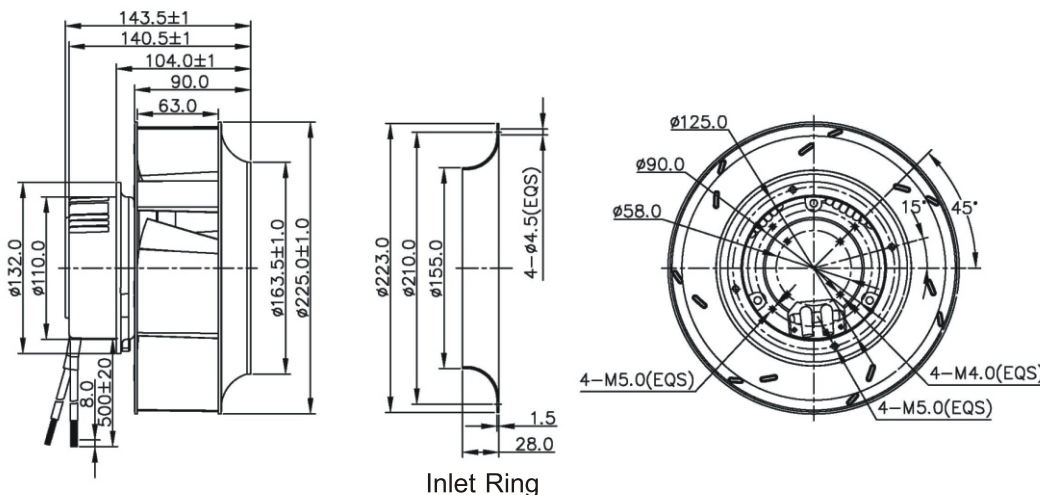

Unit:mm

**EC Motorized Impeller
Backward Curved
Ø250x80mm**



Impeller:	Galvanized Metal Sheet
Motor:	Brushless External Motor
Rotor:	Black Paint
Bearing:	Dual Ball Bearing
Insulation:	Class "A" or "B"
Operating Volt. Range:	95VAC to 138VAC for 115V Type 185VAC to 280VAC for 230V Type
Technical Features:	0-10VDC/PWM Speed Control; Tachometer Output; Locked Rotor Protection; Current Limited; Soft Start.
Operating Temp.:	-20°C to +60°C
Weight:	2770 g

Model Number	Voltage (VAC)	Frequency (Hz)	AirFlow (CFM)	Air Flow (m ³ /H)	StaticPres. (mm-H ₂ O)	StaticPres. (inH ₂ O)	Noise (dBA)	Speed (RPM)	Current (mA)	Power (W)	Curves
FEI25080B11W9-57	115	50/60	872.70	1482.60	77.50	3.10	74.60	2,900	2700	201.00	①
FEI25080B22W9-57	230	50/60	872.70	1482.60	77.50	3.10	74.60	2,900	1350	201.00	①

Specifications are subject to change without notice

Characteristic Curves:

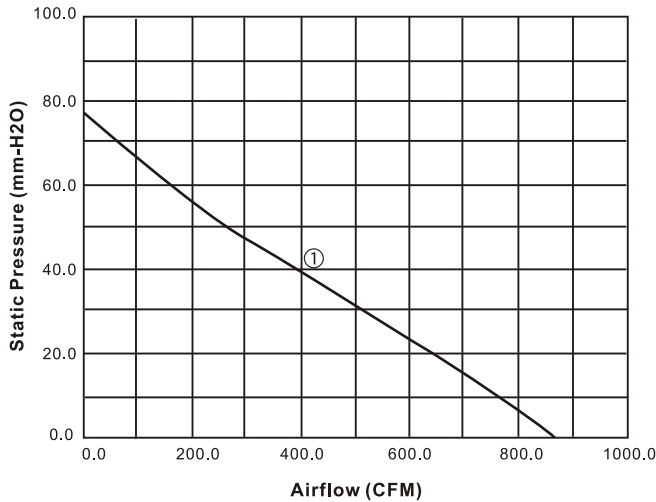

Outline Drawing:

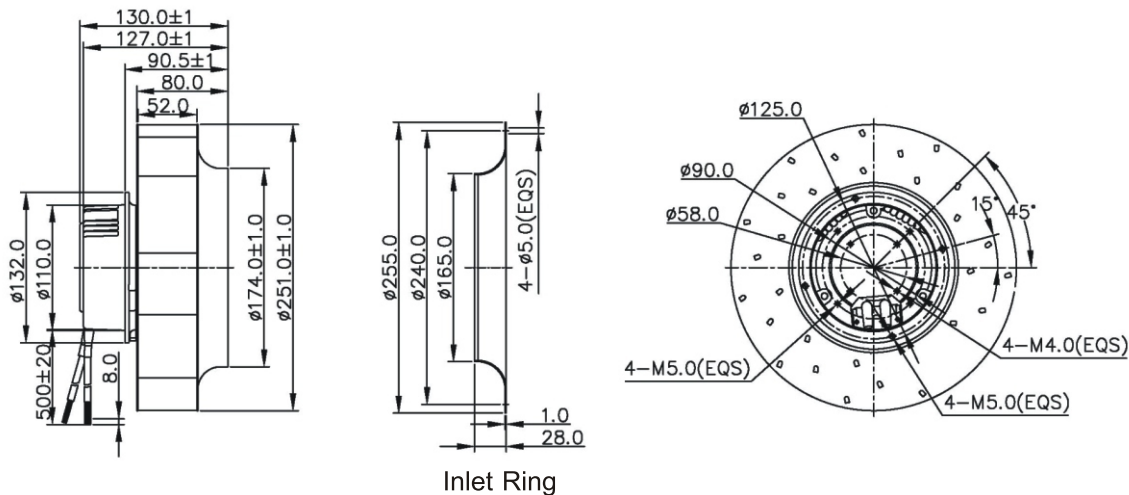

Unit:mm

**EC Motorized Impeller
Backward Curved
Ø250x110mm**



Impeller:	Aluminum Sheet
Motor:	Brushless External Motor
Rotor:	Black Paint
Bearing:	Dual Ball Bearing
Insulation:	Class "A" or "B"
Operating Volt. Range:	95VAC to 138VAC for 115V Type 185VAC to 280VAC for 230V Type
Technical Features:	0-10VDC/PWM Speed Control; Tachometer Output; Locked Rotor Protection; Current Limited; Soft Start.
Operating Temp.:	-20°C to +60°C
Weight:	6000 g

Model Number	Voltage (VAC)	Frequency (Hz)	AirFlow (CFM)	Air Flow (m ³ /H)	StaticPres. (mm-H ₂ O)	StaticPres. (inH ₂ O)	Noise (dBA)	Speed (RPM)	Current (mA)	Power (W)	Curves
FEI250110B11W9-57	115	50/60	1122.20	1906.10	80.40	3.20	74.60	3,200	6000	400.00	①
FEI250110B22W9-57	230	50/60	1122.20	1906.10	80.40	3.20	74.60	3,200	3000	400.00	①

Specifications are subject to change without notice

Characteristic Curves:

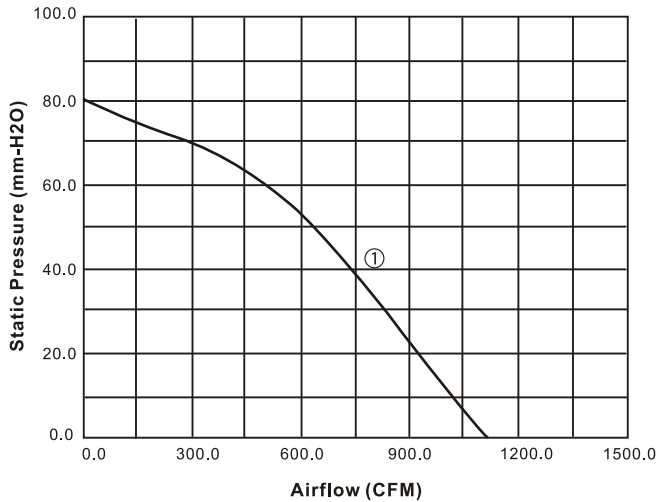

Outline Drawing:

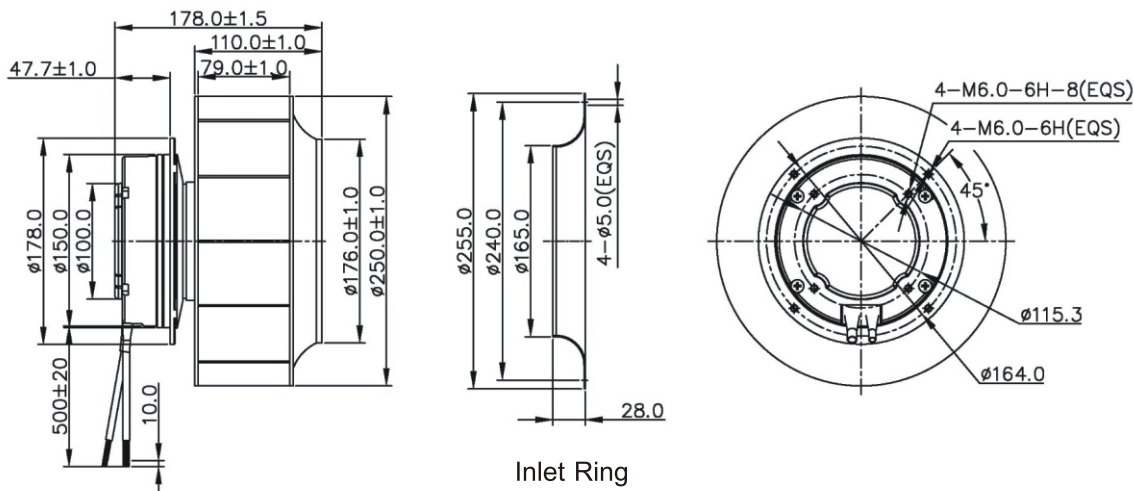

Unit:mm

**EC Motorized Impeller
Backward Curved
Ø280x112mm**



Impeller:	Galvanized Metal Sheet
Motor:	Brushless External Motor
Rotor:	Black Paint
Bearing:	Dual Ball Bearing
Insulation:	Class "A" or "B"
Operating Volt. Range:	95VAC to 138VAC for 115V Type 185VAC to 280VAC for 230V Type
Technical Features:	0-10VDC/PWM Speed Control; Tachometer Output; Locked Rotor Protection; Current Limited; Soft Start.
Operating Temp.:	-20°C to +60°C
Weight:	3800 g

Model Number	Voltage (VAC)	Frequency (Hz)	AirFlow (CFM)	AirFlow (m ³ /H)	StaticPres. (mm-H ₂ O)	StaticPres. (inH ₂ O)	Noise (dBA)	Speed (RPM)	Current (mA)	Power (W)	Curves
FEI280112B11W7-57	115	50/60	1065.50	1810.10	48.40	1.90	75.60	1,900	2000	145.00	①
FEI280112B22W7-57	230	50/60	1065.50	1810.10	48.40	1.90	75.60	1,900	1000	145.00	①

Specifications are subject to change without notice

Characteristic Curves:

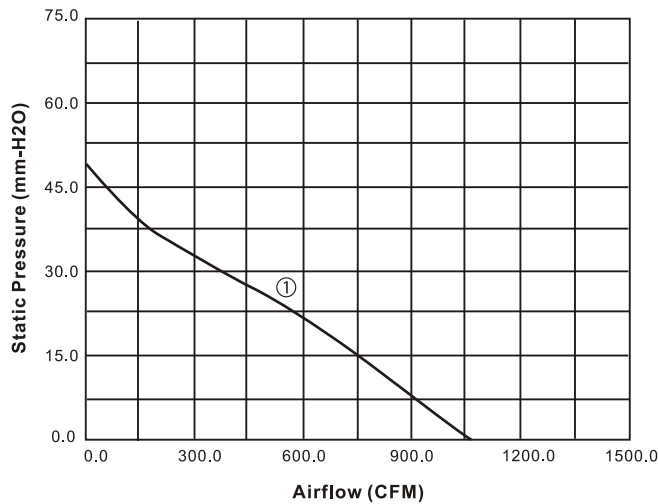

Outline Drawing:

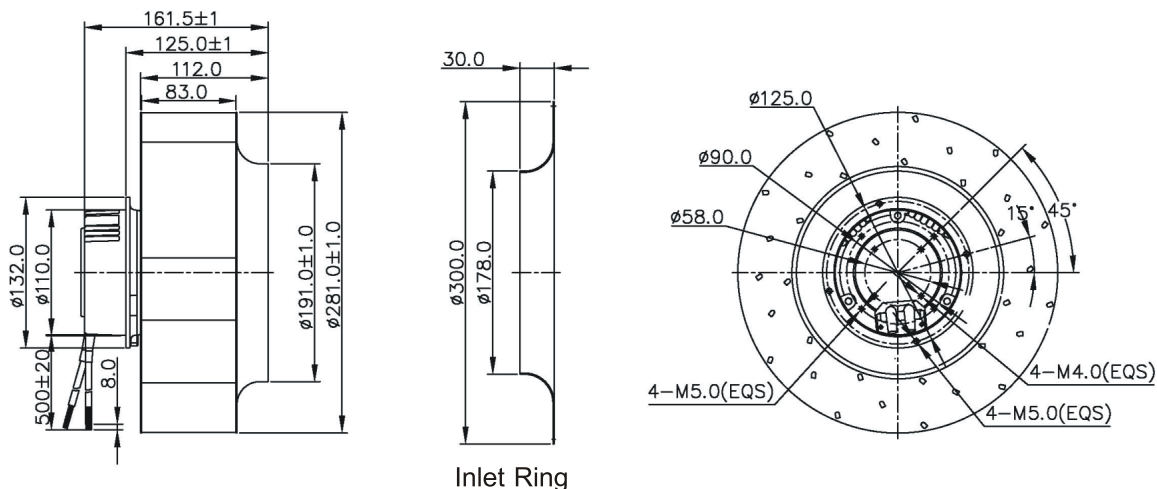

Unit:mm

**EC Motorized Impeller
Backward Curved
Ø280x112mm**

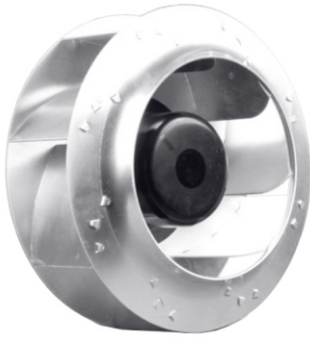

Impeller:	Aluminum Sheet
Motor:	Brushless External Motor
Rotor:	Black Paint
Bearing:	Dual Ball Bearing
Insulation:	Class "A" or "B"
Operating Volt. Range:	95VAC to 138VAC for 115V Type 185VAC to 280VAC for 230V Type
Technical Features:	0-10VDC/PWM Speed Control; Tachometer Output; Locked Rotor Protection; Current Limited; Soft Start.
Operating Temp.:	-20°C to +60°C
Weight:	4460 g

Model Number	Voltage (VAC)	Frequency (Hz)	AirFlow (CFM)	Air Flow (m ³ /H)	StaticPres. (mm-H ₂ O)	StaticPres. (inH ₂ O)	Noise (dBA)	Speed (RPM)	Current (mA)	Power (W)	Curves
FEI280112B11W9-57	115	50/60	1604.90	2726.40	89.00	3.50	74.60	3,000	6800	500.00	①
FEI280112B22W9-57	230	50/60	1604.90	2726.40	89.00	3.50	74.60	3,000	3400	500.00	①

Specifications are subject to change without notice

Characteristic Curves:

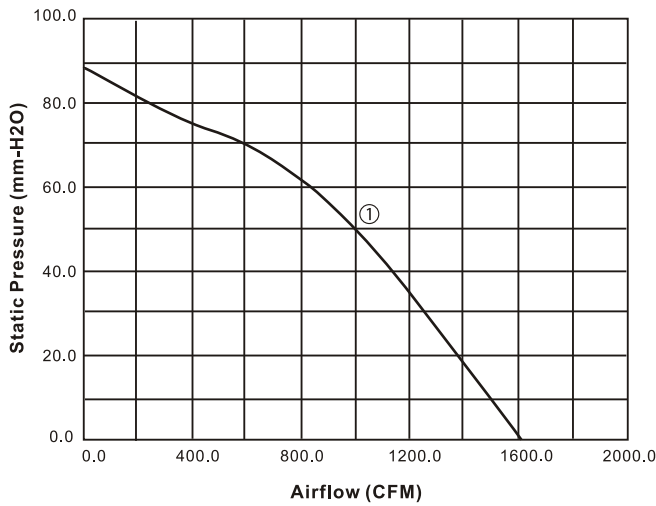

Outline Drawing:

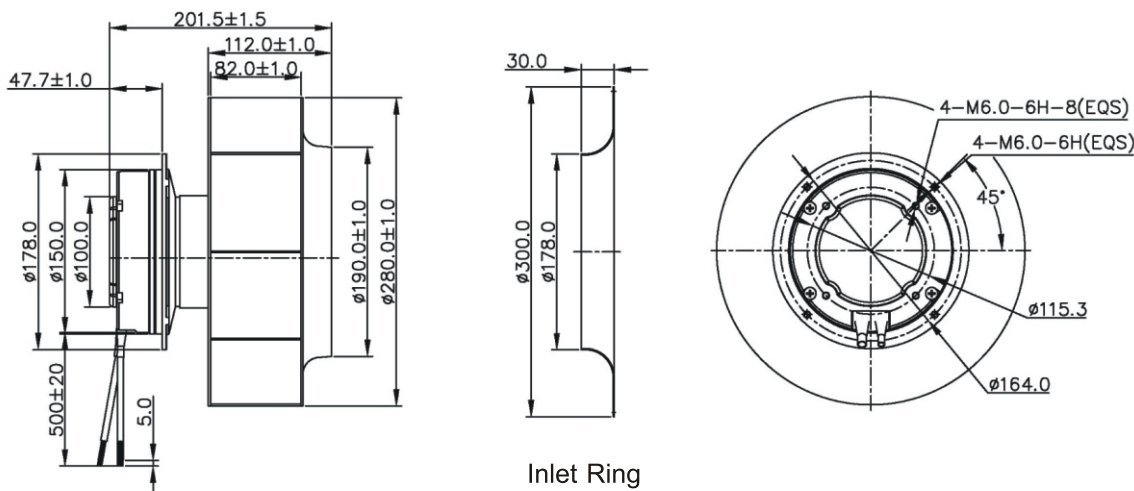

**EC Motorized Impeller
Backward Curved
Ø310x108mm**



Impeller:	Aluminum Sheet
Motor:	Brushless External Motor
Rotor:	Black Paint
Bearing:	Dual Ball Bearing
Insulation:	Class "A" or "B"
Operating Volt. Range:	95VAC to 138VAC for 115V Type 185VAC to 280VAC for 230V Type
Technical Features:	0-10VDC/PWM Speed Control; Tachometer Output; Locked Rotor Protection; Current Limited; Soft Start.
Operating Temp.:	-20°C to +60°C
Weight:	3100 g

Model Number	Voltage (VAC)	Frequency (Hz)	AirFlow (CFM)	AirFlow (m ³ /H)	StaticPres. (mm-H ₂ O)	StaticPres. (inH ₂ O)	Noise (dBA)	Speed (RPM)	Current (mA)	Power (W)	Curves
FEI310108B11W5-57	115	50/60	1124.20	1909.30	53.00	2.10	54.70	1,700	1800	140.00	①
FEI310108B22W5-57	230	50/60	1124.20	1909.30	53.00	2.10	54.70	1,700	950	140.00	①

Specifications are subject to change without notice

Characteristic Curves:

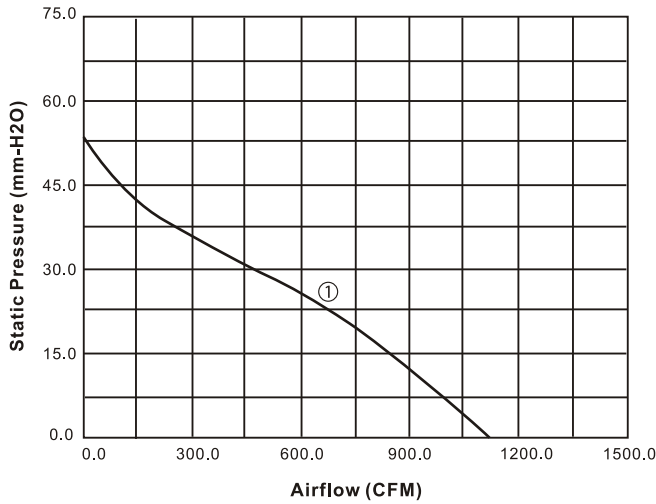

Outline Drawing:

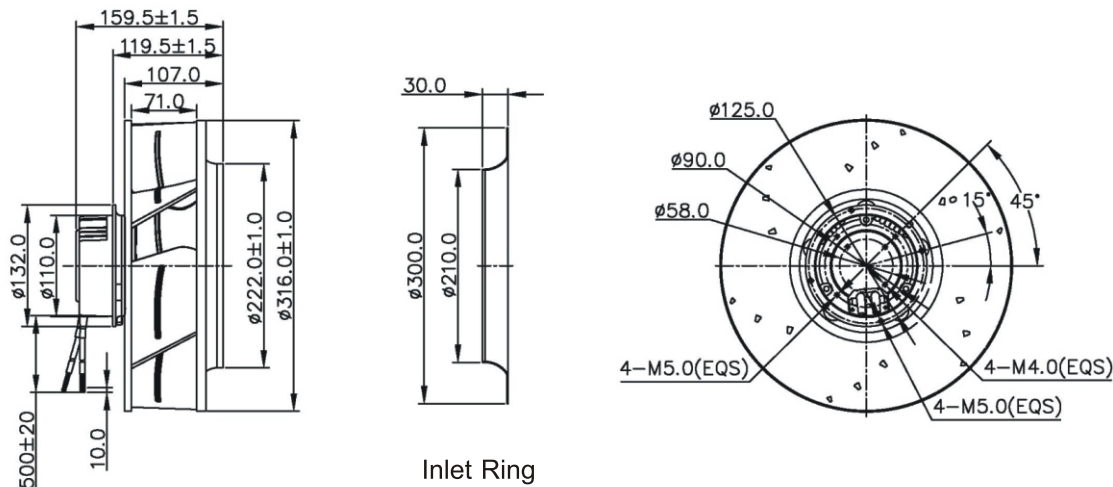

Unit:mm

**EC Motorized Impeller
Backward Curved
Ø310x108mm**



Impeller:	Aluminum Sheet
Motor:	Brushless External Motor
Rotor:	Black Paint
Bearing:	Dual Ball Bearing
Insulation:	Class "A" or "B"
Operating Volt. Range:	95VAC to 138VAC for 115V Type 185VAC to 280VAC for 230V Type
Technical Features:	0-10VDC/PWM Speed Control; Tachometer Output; Locked Rotor Protection; Current Limited; Soft Start.
Operating Temp.:	-20°C to +60°C
Weight:	4300 g

Model Number	Voltage (VAC)	Frequency (Hz)	AirFlow (CFM)	AirFlow (m ³ /H)	StaticPres. (mm-H ₂ O)	StaticPres. (inH ₂ O)	Noise (dBA)	Speed (RPM)	Current (mA)	Power (W)	Curves
FEI310108B11W7-57	115	50/60	1562.80	2656.20	85.10	3.40	70.60	2,350	4200	390.00	①
FEI310108B22W7-57	230	50/60	1562.80	2656.20	85.10	3.40	70.60	2,350	2500	390.00	①

Specifications are subject to change without notice

Characteristic Curves:

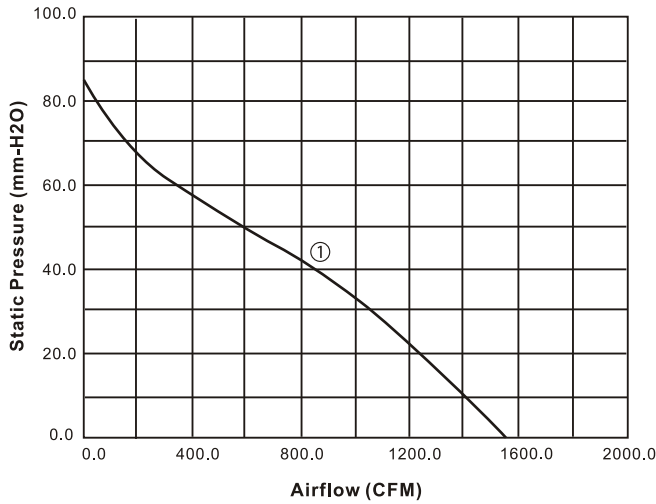

Outline Drawing:

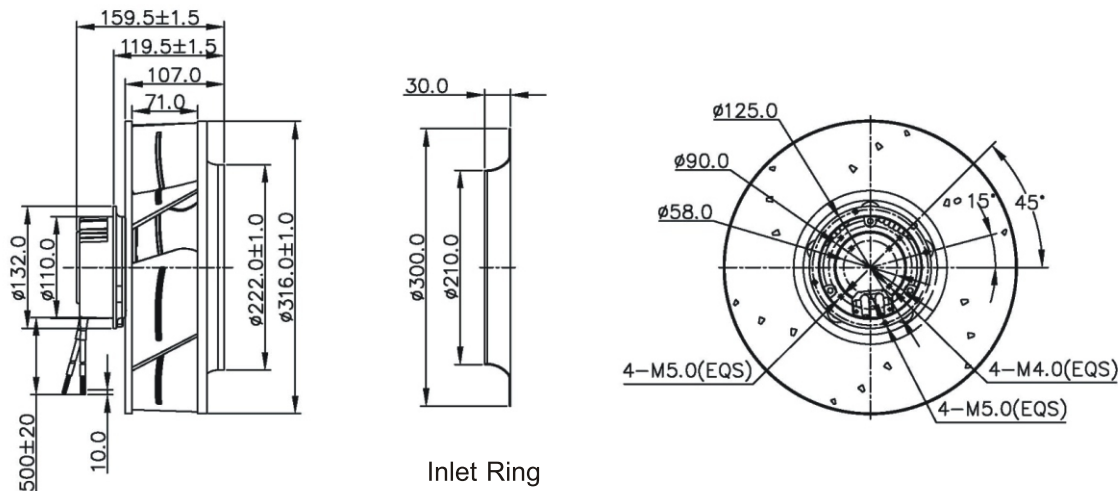

Unit:mm

**EC Motorized Impeller
Backward Curved
Ø310x140mm**



Impeller:	Aluminum Sheet
Motor:	Brushless External Motor
Rotor:	Black Paint
Bearing:	Dual Ball Bearing
Insulation:	Class "A" or "B"
Operating Volt. Range:	95VAC to 138VAC for 115V Type 185VAC to 280VAC for 230V Type
Technical Features:	0-10VDC/PWM Speed Control; Tachometer Output; Locked Rotor Protection; Current Limited; Soft Start.
Operating Temp.:	-20°C to +60°C
Weight:	3160 g

Model Number	Voltage (VAC)	Frequency (Hz)	AirFlow (CFM)	AirFlow (m ³ /H)	StaticPres. (mm-H ₂ O)	StaticPres. (inH ₂ O)	Noise (dBA)	Speed (RPM)	Current (mA)	Power (W)	Curves
FEI310140B11W5-57	115	50/60	1295.10	2200.10	47.90	1.90	56.70	1,600	1800	140.00	①
FEI310140B22W5-57	230	50/60	1295.10	2200.10	47.90	1.90	56.70	1,600	950	140.00	①

Specifications are subject to change without notice

Characteristic Curves:

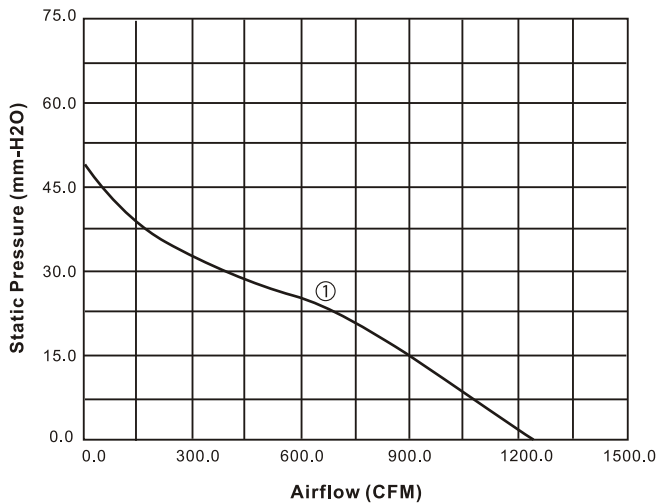

Outline Drawing:

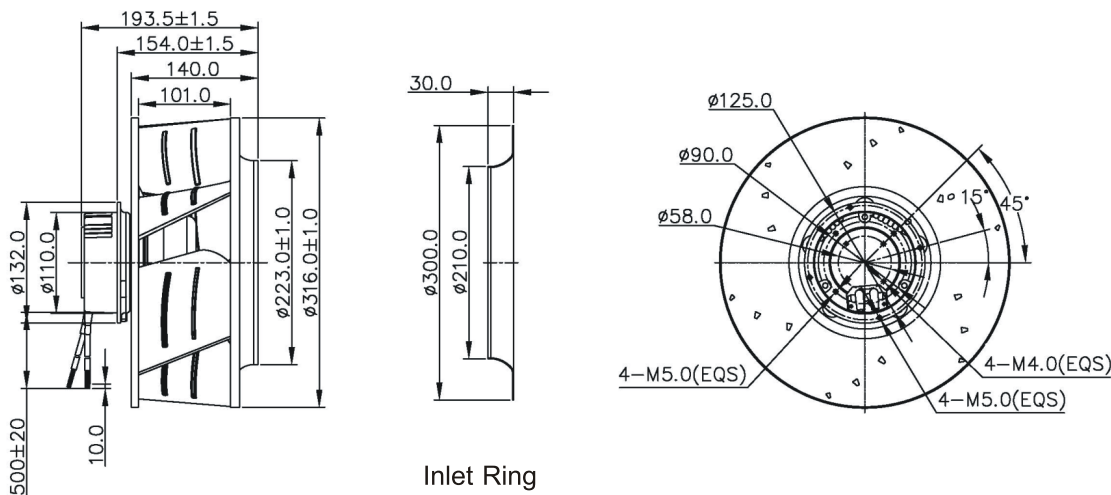

Inlet Ring

Unit:mm

**EC Motorized Impeller
Backward Curved
Ø310x140mm**



Impeller:	Aluminum Sheet
Motor:	Brushless External Motor
Rotor:	Black Paint
Bearing:	Dual Ball Bearing
Insulation:	Class "A" or "B"
Operating Volt. Range:	95VAC to 138VAC for 115V Type 185VAC to 280VAC for 230V Type
Technical Features:	0-10VDC/PWM Speed Control; Tachometer Output; Locked Rotor Protection; Current Limited; Soft Start.
Operating Temp.:	-20°C to +60°C
Weight:	4600 g

Model Number	Voltage (VAC)	Frequency (Hz)	AirFlow (CFM)	Air Flow (m ³ /H)	StaticPres. (mm-H ₂ O)	StaticPres. (inH ₂ O)	Noise (dBA)	Speed (RPM)	Current (mA)	Power (W)	Curves
FEI310140B11W7-57	115	50/60	1811.60	3077.50	87.20	3.40	74.60	2,350	4200	390.00	①
FEI310140B22W7-57	230	50/60	1811.60	3077.20	87.20	3.40	74.60	2,350	2600	390.00	①

Specifications are subject to change without notice

Characteristic Curves:

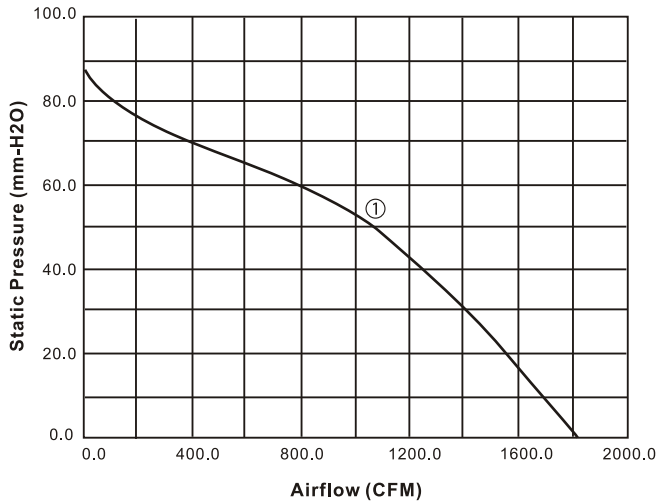

Outline Drawing:

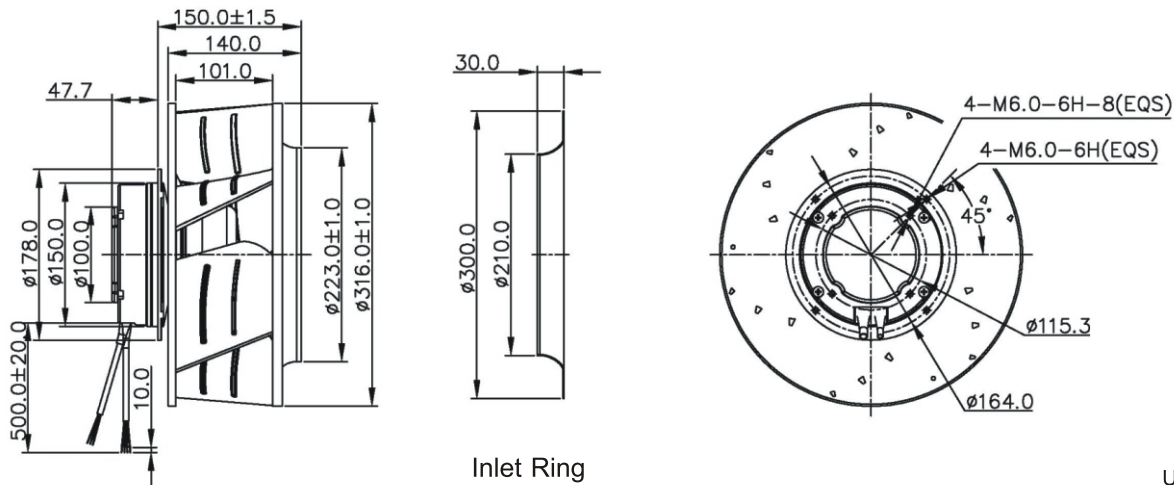

**EC Motorized Impeller
Backward Curved
Ø355x147mm**

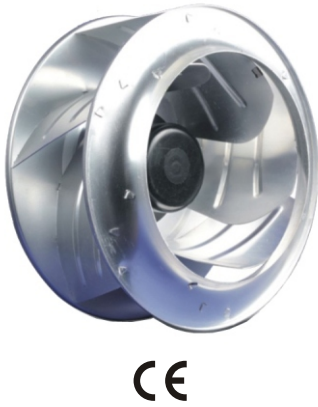

Impeller:	Aluminum Sheet
Motor:	Brushless External Motor
Rotor:	Black Paint
Bearing:	Dual Ball Bearing
Insulation:	Class "A" or "B"
Operating Volt. Range:	95VAC to 138VAC for 115V Type 185VAC to 280VAC for 230V Type
Technical Features:	0-10VDC/PWM Speed Control; Tachometer Output; Locked Rotor Protection; Current Limited; Soft Start.
Operating Temp.:	-20°C to +60°C
Weight:	5200 g

Model Number	Voltage (VAC)	Frequency (Hz)	AirFlow (CFM)	AirFlow (m ³ /H)	StaticPres. (mm-H ₂ O)	StaticPres. (inH ₂ O)	Noise (dBA)	Speed (RPM)	Current (mA)	Power (W)	Curves
FEI355147B11W9-57	115	50/60	1818.50	3089.40	81.70	3.20	72.60	1,950	5200	400.00	①
FEI355147B22W9-57	230	50/60	1818.50	3089.40	81.70	3.20	72.60	1,950	2600	400.00	①

Specifications are subject to change without notice

Characteristic Curves:

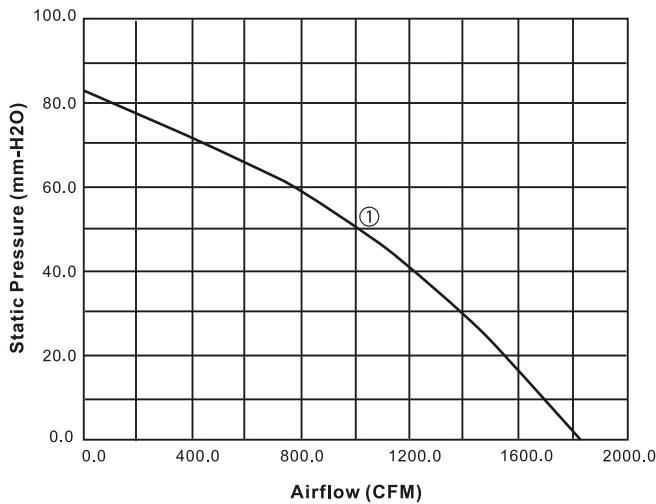

Outline Drawing:

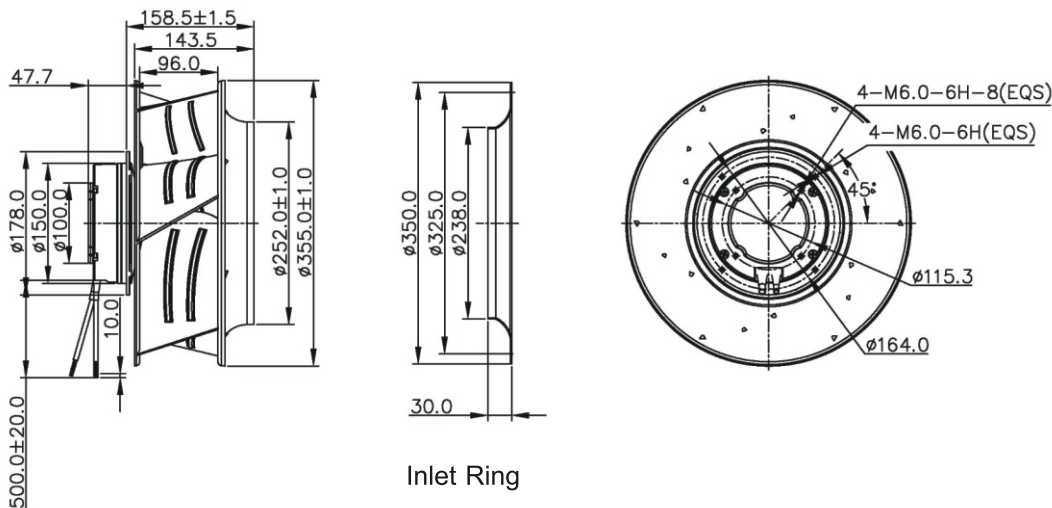

**EC Motorized Impeller
Backward Curved
Ø404x141 mm**



Impeller:	Aluminum Sheet
Motor:	Brushless External Motor
Rotor:	Black Paint
Bearing:	Dual Ball Bearing
Insulation:	Class "A" or "B"
Operating Volt. Range:	95VAC to 138VAC for 115V Type 185VAC to 280VAC for 230V Type
Technical Features:	0-10VDC/PWM Speed Control; Tachometer Output; Locked Rotor Protection; Current Limited; Soft Start.
Operating Temp.:	-20°C to +60°C
Weight:	5600 g

Model Number	Voltage (VAC)	Frequency (Hz)	AirFlow (CFM)	AirFlow (m ³ /H)	StaticPres. (mm-H ₂ O)	StaticPres. (inH ₂ O)	Noise (dBA)	Speed (RPM)	Current (mA)	Power (W)	Curves
FEI404141B11W7-57	115	50/60	2111.30	3586.50	72.10	2.80	70.70	1,550	4900	360.00	①
FEI404141B22W9-57	230	50/60	2401.70	3586.50	90.10	2.80	73.60	1,700	3300	360.00	②

Specifications are subject to change without notice

Characteristic Curves:

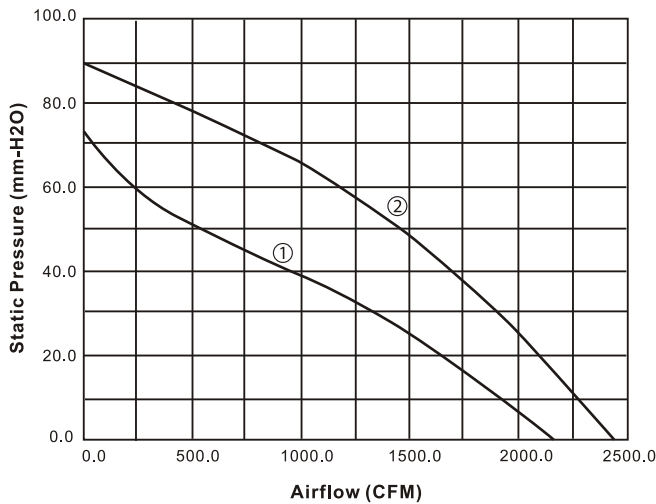

Outline Drawing:

