



INNOVATIVE COMPONENTS, INC.

Manufacturers of Plastic Clamping
Knobs, Quick Release Pins, Wire
Rope Lanyards, and Thread
Identifiers



KNOBS

3-Prong | 4-Prong / 4-Lobe | Star | Fluted | Ball | Tapered | Push / Pull | Knurled
Press-On Thumb Screws | T | Snap-Lock | Universal Ball / Tapered | Press Fit
Metal Knurled | Quick Release | Control | Pad Printing & Laser Etching | Custom Molding

1

QUICK RELEASE COMPONENTS

Ring Detent | Threaded Detent | Ring | Clevis | Adjustable Clevis | Cotterless Clevis
Hitch | Wire Lock | Knob Detent | Magnetic Selector | Swell Latch

2

SPRING LOADED PINS

Positive Locking | Pin Receptacles | Pop | Plunger

3

LANYARDS

Coiled Plastic | Wire Rope

4

HANDLES

Adjustable

5

THREAD IDENTIFIERS

Mini | Standard | Jumbo | Lug | Pipe

6

ENGINEERED COMPONENTS

Secondary Machining | Nylon Tipped Fasteners | CNC & Screw Machine Parts

7



Mission Statement

Innovative Components provides high quality products at competitive prices, through excellence in manufacturing and service, to ensure continued customer success while encouraging innovation.

Core Values

Our everyday work and approach to business are guided by our five company core values:

Respect

We treat our customers, vendors and our employees with respect as this is a direct reflection of our character, integrity and values as a company.

Teamwork

We believe that by working together as a team to achieve a common goal, we can achieve more than an individual.

Continuous Improvement

We maintain a standing commitment to continuous improvement and excellence in productivity, processes, personal development, products, and services.

Service

We strive to be a great corporate partner in supporting and improving our communities that we live and work in. We are committed to community involvement and social responsibility.

Integrity

We believe without integrity, nothing else matters.

Our Capabilities

- Plastic Injection Molding
- Over Molding
- Design & Engineering
- CNC Machining
- Secondary Machining (ie. Shaving, Slotting, Drilling)
- Tool Design, Mold Making, & Maintenance
- Light Assembly
- Pad Printing
- Laser Etching
- Bagging
- Kitting
- 3D Printing
- 3D CAD

KNOBS

- 6** 3-Prong
- 7** 4-Prong / 4-Lobe
- 8** Star
- 8** Ergo Star
- 9** Fluted
- 10** Tapered
- 10** Push / Pull
- 11** Ball
- 12** T
- 13** Knurled
- 14** Snap-Lock
- 15** Press-On Thumb Screws
- 17** Universal Ball / Tapered
- 18** Press Fit
- 19** Metal Knurled
- 19** Quick Release
- 20** Control
- 20** Pointer
- 21** Pad Printing & Laser Etching
- 21** Custom Molding



3-Prong Knobs

Knob Style	A	B	C	D
RT2	.75"	.50"	.23"	.51"
3P1	1.25"	.62"	.50"	.95"
3P1C	1.25"	.62"	.26"	.72"
3P2	1.40"	.61"	.51"	1.06"
3P4	1.75"	.75"	.49"	1.05"
TK4	1.74"	.58"	.36"	.86"
3P4C	1.75"	.75"	.26"	.82"
3P4A»	1.75"	.75" / .57"	1.25"	1.82"
3L4	1.76"	.75"	.34"	.85"
3W4	1.78"	.75"	.32"	.84"
TK5	1.90"	.58"	.39"	1.00"
RT5	2.02"	.74"	.49"	1.10"
RT5C	2.02"	.74"	.25"	.86"
TK7	2.45"	.83"	.50"	1.25"
RT7	2.52"	.74"	.48"	1.12"

» Hub is Chamfered.
 * Dimension "C" may be changed upon request. Engineering charges may apply to certain sizes.

Male & Female Insert Sizes Available

Knob Style	#8	#10	1/4	5/16	3/8
	M4	M5	M6	M8	M10
RT2	✓	✓	✓		
3P1	✓	✓	✓	✓	•
TK4	✓	✓	✓	✓	•
3P2	✓	✓	✓	✓	•
3P4	✓	✓	✓	✓	✓
3L4	✓	✓	✓	✓	✓
3W4	✓	✓	✓	✓	✓
TK5	✓	✓	✓	✓	•
RT5	✓	✓	✓	✓	✓
TK7	✓	✓	✓	✓	✓
RT7	✓	✓	✓	✓	✓

• Female Threads Only

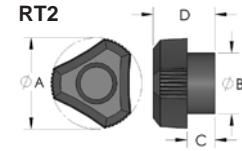

3P1 / 3P4

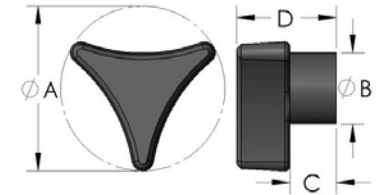

3P2

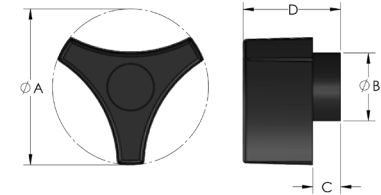

3L4



3W4



TK4 / TK7

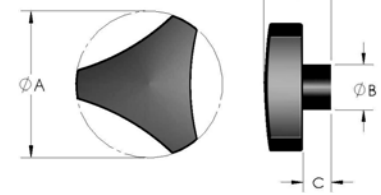

RT5 / RT7 / TK5

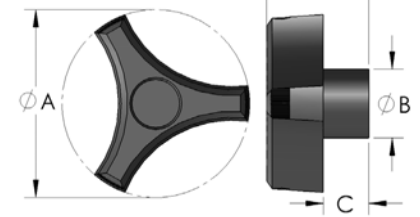

4-Prong / 4-Lobe Knobs

Knob Style	A	B	C	D
4S1	1.15"	.50"	.25"	.65"
4S2Δ	1.40"	.55"	.18"	.64"
4S2AΔ	1.40"	.75"	.25"	.72"
4P3	1.48"	.625"	.50"	.95"
4S4Δ	1.73"	.75"	.25"	.82"
4S4AΔ	1.73"	.75"	.13"	.69"
4L4	1.74"	.75"	.35"	.86"
4L5	1.74"	.75"	.35"	.85"
4P4	1.75"	.75"	.52"	1.02"
4P5	1.98"	.73"	.41"	1.11"
4S5Δ	2.00"	.75"	.18"	.98"
4P7	2.46"	.98"	.48"	1.13"

Available in Soft Touch TPE Material
Δ Available in Two Tone
 * Dimension "C" may be changed upon request. Engineering charges may apply to certain sizes.

Male & Female Insert Sizes Available

Knob Style	#8	#10	1/4	5/16	3/8	7/16	1/2
	M4	M5	M6	M8	M10	M12	M14
4S1 / 4S2	✓	✓	✓				
4S2I	✓	✓	✓	✓	✓		
4P3	✓	✓	✓	✓			
4S4	✓	✓	✓	✓	✓		
4L4	✓	✓	✓	✓	✓		
4L5	✓	✓	✓	✓	✓		
4P4	✓	✓	✓	✓	✓		
4P5	✓	✓	✓	✓	✓		
4S5	✓	✓	✓	✓	✓		
4P7	✓	✓	✓	✓	✓	✓	✓

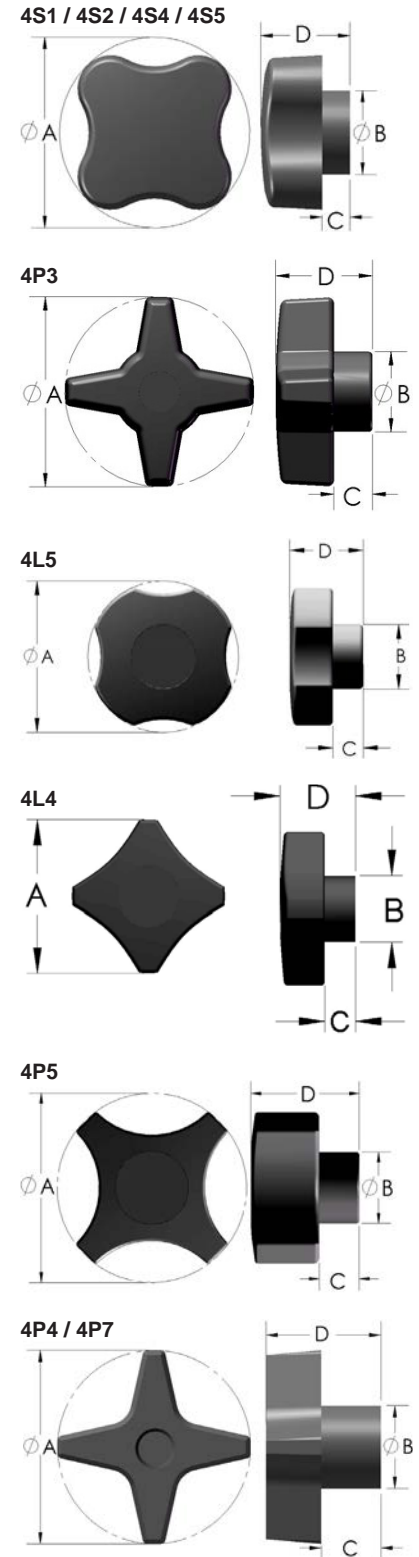

Star Knobs

Knob Style	A	B	C	D
5S2	1.38"	.86"	.70"	1.15"
5S2A	1.38"	.86"	.72"	1.17"
5S2B	1.38"	.86"	.75"	1.20"
5S2C	1.38"	.86"	.25"	.69"
5S2E	1.38"	.86"	1.125"	1.58"
5S3	1.75"	.88"	.75"	1.25"
5S3A	1.75"	.88"	.49"	.99"
5S3C	1.75"	.88"	1.50"	2.00"
5S3D	1.75"	.88"	.125"	.63"
5S3E	1.75"	.88"	.25"	.75"
5S4	2.27"	.98"	.12"	.61"
5SA	2.27"	.98"	.47"	1.00"
5SB	2.27"	.98"	.25"	.73"
EP6	3.46"	1.22"	.55"	1.47"

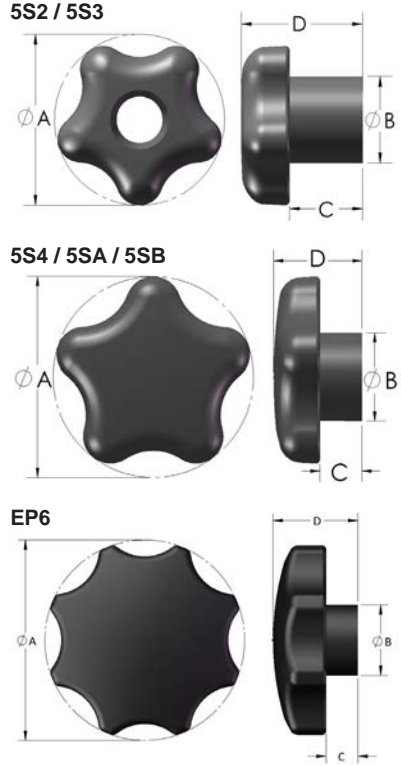

* Dimension "C" may be changed upon request. Engineering charges may apply to certain sizes.

Male & Female Insert Sizes Available

Knob Style	#8	#10	1/4	5/16	3/8	7/16	1/2	5/8
	M4	M5	M6	M8	M10	M12	M14	M16
5S2	✓	✓	✓	✓	✓	✓		
5S3	✓	✓	✓	✓	✓	✓		
5S4	✓	✓	✓	✓	✓	✓	✓	
5SA	✓	✓	✓	✓	✓	✓	✓	
5SB	✓	✓	✓	✓	✓	✓	✓	
EP6	✓	✓	✓	✓	✓	✓	✓	✓

Ergo Star Knobs

Knob Style	A	B	C	D
R2	1.31"	.70"	.18"	.96"
R3Δ	1.58"	.74"	.25"	1.15"
R3SΔ	1.58"	.70"	.18"	1.08"
R5Δ	2.00"	.74"	.18"	1.22"
R5SΔ	2.00"	.74"	.18"	1.22"
R7SΔ	2.42"	1.00"	.20"	1.26"

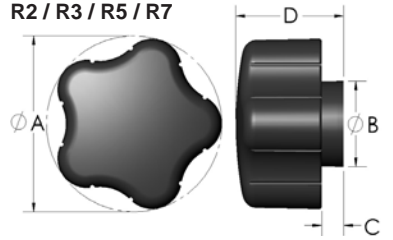

Two Tone (Available in R3 / R5 / R7)



 Available in Soft Touch TPE Material - The "S" in Knob Style Denotes Soft Touch TPE Material.
 Δ Available in Two Tone
 * Dimension "C" may be changed upon request. Engineering charges may apply to certain sizes.

Male & Female Insert Sizes Available

Knob Style	#8	#10	1/4	5/16	3/8	7/16	1/2
	M4	M5	M6	M8	M10	M12	M14
R2 / R3 / R3S / R5S	✓	✓	✓	✓	✓		
R5 / R7S	✓	✓	✓	✓	✓	✓	✓

Fluted Knobs

Knob Style	A	B	C	D
A1	.88"	.63"	.13"	.50"
TF1	1.00"	.55"	.125"	.872"
F2	1.36"	.98"	.17"	.53"
F2B	1.36"	.63"	.52"	.87"
F2C	1.36"	.98"	.235"	.625"
TF3	1.50"	.68"	.634"	1.75"
A3	1.50"	.69"	.38"	.75"
O3	1.50"	.375"	.78"	.475"
F4	1.72"	1.23"	.28"	.86"
F4A	1.72"	1.23"	.60"	1.18"
TF5	1.95"	.80"	.46"	2.20"
F6	2.38"	1.25"	.62"	1.23"
F6D	2.38"	.75"	.63"	1.25"
F6E	2.38"	.75"	.20"	.80"
F6F	2.38"	1.25"	.10"	.72"
F6G	2.38"	.88"	.80"	1.37"
F6H	2.38"	.75"	.30"	1.00"
F6J	2.38"	.84"	1.00"	1.60"
F6K	2.38"	1.25"	.12"	.82"
F7SΔ	2.48"	1.25"	.57"	1.29"

- Available in Soft Touch TPE Material
- Δ Available in Two Tone
- * Dimension "C" may be changed upon request. Engineering charges may apply to certain sizes.
- * Hub Tapers on TF3 & TF5

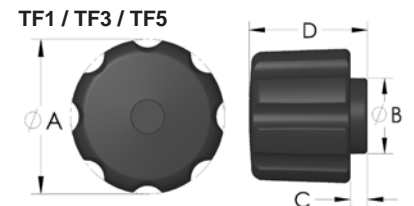
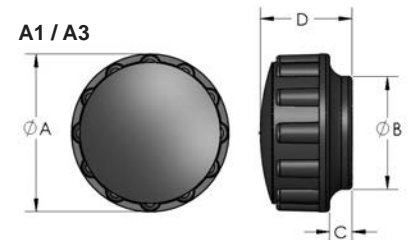
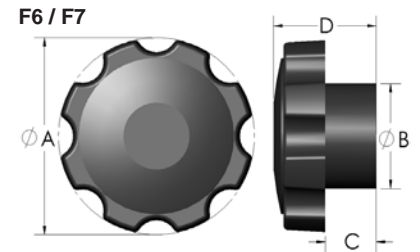
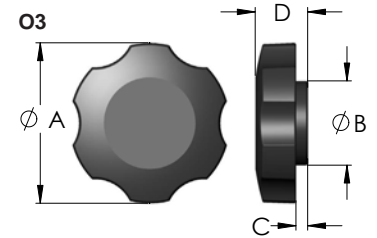
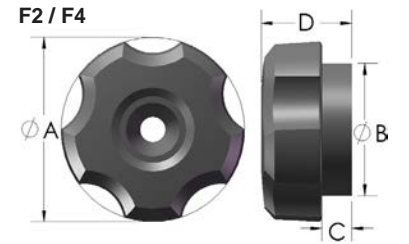

Two Tone (Available in F7 Only)



Male & Female Insert Sizes Available

Knob Style	#8	#10	1/4	5/16	3/8	7/16	1/2	5/8
	M4	M5	M6	M8	M10	M12	M14	M16
A1 / A3 / F2	✓	✓	✓	✓	✓			
O3	✓	✓	✓					
F4	✓	✓	✓	✓	✓	✓	✓	✓
F6 / F6F / F6G / F6J / F6K	✓	✓	✓	✓	✓	✓	✓	✓
F6D / F6E / F6H	✓	✓	✓	✓	✓			
F7	✓	✓	✓	✓	✓	✓	✓	✓
TF1	✓	✓	✓•	✓•				
TF3	✓	✓	✓	✓	✓•	✓•		
TF5	✓	✓	✓	✓	✓	✓	✓•	

- Must Use Knurled Inserts for this Thread Size to Fit

Tapered Knobs

Knob Style	A	B	C
S1	1.00"	.50"	1.61"
L2	1.11"	.76"	3.85"
LF2	1.11"	.76"	3.30"
SD	1.125"	.56"	1.44"
L3	1.36"	1.00"	4.12"
S3	1.38"	.92"	2.00"
SF3	1.37"	.92"	1.44"
S5	1.60"	1.00"	2.42" (ref)

Available in Soft Touch TPE Material - The "S" in Knob Style Denotes Soft Touch TPE Material.

Male & Female Insert Sizes Available

Knob Style	#8	#10	1/4	5/16	3/8	7/16	1/2	5/8
	M4	M5	M6	M8	M10	M12	M14	M16
SD / S1	✓	✓	✓	✓				
S3 / S3S / SF3	✓	✓	✓	✓	✓	✓	✓	
S5 / S5S / L2 / LF2 / L3	✓	✓	✓	✓	✓	✓	✓	✓

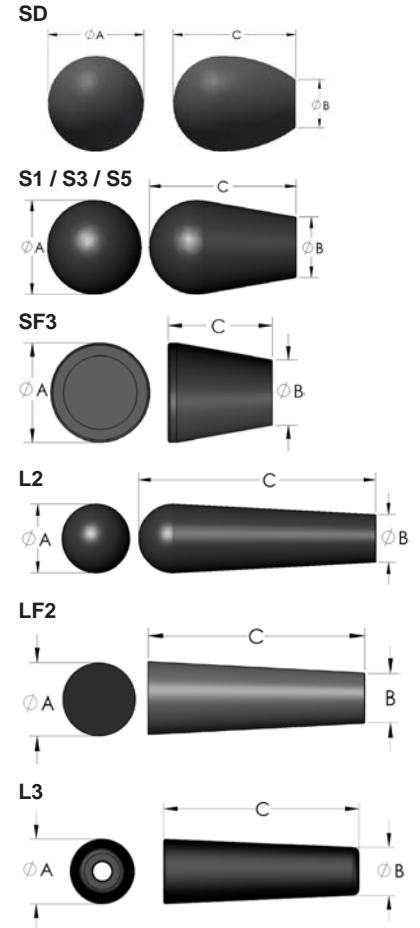

Push / Pull Knobs

Knob Style	A	B	C	D
PL3	.82"	.53"	.66"	.75"
PL4	1.00"	.53"	.68"	.93"
DP2	1.24"	.68"	1.12"	1.22"
PL5*	1.63"	.75"	.78"	1.16"
PL5A	1.63"	.75"	1.30"	1.70"

* Dimension "C" may be changed upon request. Engineering charges may apply to certain sizes.

Male & Female Insert Sizes Available

Knob Style	#8	#10	1/4	5/16	3/8
	M4	M5	M6	M8	M10
PL3	✓	✓	✓		
PL4 / DP2 / PL5 / PL5A	✓	✓	✓	✓	✓

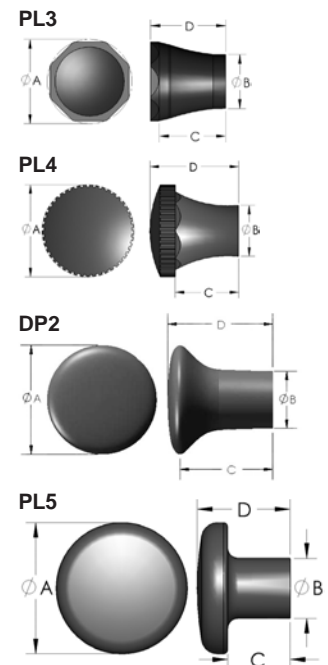

Ball Knobs

Plastic & Metal

Knob Style	A	B	C
B0*	.75"	.37"	.70"
B1*	1.00"	.62"	.88"
B2*	1.25"	.62"	1.15"
B3*	1.38"	.75"	1.28"
B4*	1.47"	.75"	1.40"
B5*	1.61"	.75"	1.52"
B7*	1.88"	1.00"	1.75"

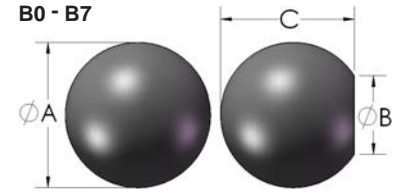

Available in Soft Touch TPE Material
 * Also Available in Poly Pro, ABS, Nylon, or Metal

Shoulder Style

Knob Style	A	B	C	D
SB0*	.75"	.37"	.12"	.82"
SB1*	1.00"	.62"	.16"	1.07"
SB2*	1.25"	.62"	.37"	1.52"
SB3*	1.38"	.75"	.12"	1.40"
SB4*	1.50"	.75"	.12"	1.52"
SB5*	1.63"	.75"	.25"	1.77"
SB7*	1.88"	.75"	.38"	2.13"

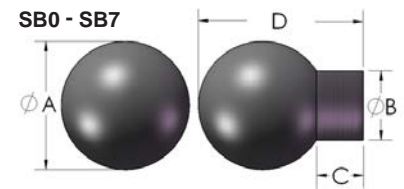

* Shoulder Style

Available in Soft Touch TPE Material
 * Shoulders can be adjusted per customer requirements. Engineering charges may apply to certain sizes.

Half Ball Style

Knob Style	A	B	C	D
H3	1.37"	.75"	.12"	.85"

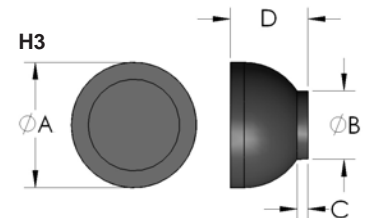

Male & Female Insert Sizes Available

Knob Style	#8	#10	1/4	5/16	3/8	7/16	1/2	5/8	3/4
	M4	M5	M6	M8	M10	M12	M14	M16	M20
B0/SB0	✓	✓	✓						
B1/ SB1	✓	✓	✓	✓	✓				
B2/ SB2	✓	✓	✓	✓	✓	✓	✓		
B3/ SB3	✓	✓	✓	✓	✓	✓	✓	✓	
B4/ SB4	✓	✓	✓	✓	✓	✓	✓	✓	
B5/ SB5	✓	✓	✓	✓	✓	✓	✓	✓	
B7/ SB7	✓	✓	✓	✓	✓	✓	✓	✓	✓
H3	✓	✓	✓	✓	✓	✓	✓		

T-Knobs

Knob Style	A	B	C	D
TS2	.86"	.86" (skirt diameter)	.08"	.58"
T0*	1.02"	.48"	--	.26"
T1*	1.16"	.50"	.39"	.94"
T1A*	1.16"	.50"	.12"	.67"
T1C*	1.16"	.50"	.63"	1.15"
T1D*-	1.16"	.48"	.42"	.98"
T2*	1.25"	.54"	--	.35"
TH1	1.26"	.63"	.20"	.83"
T3*	1.50"	.63"	--	.41"
T6	1.75"	.50"	--	.80"
T5	2.00"	.75"	.49"	1.04"
T5A	2.00"	.75"	.26"	.83"
TR6*	2.27"	.77"	.57"	1.41"
T7	2.50"	.75"	.46"	1.11"
T7A	2.50"	--	--	.62"
T7B	2.50"	.68"	.61"	1.26"
T9	3.50"	.97"	.27"	1.13"
TW7	2.50"	.86"	.37"	1.10"

- Female Blind Only
- Molded Nylon Threads - Thru Hole Only
- * Dimension "C" may be changed upon request. Engineering charges may apply to certain sizes.

Male & Female Insert Sizes Available

Knob Style	#8	#10	1/4	5/16	3/8	7/16	1/2
	M4	M5	M6	M8	M10	M12	M14
T0 / TS2	✓	✓	✓				
T1 / T1A / T1C	✓	✓	✓	✓•			
T2 / T3 / TH1	✓	✓	✓	✓			
T5 / T5A / TR6 / T7 / T7A / TW7	✓	✓	✓	✓	✓		
T9	✓	✓	✓	✓	✓	✓	✓

- Female Threads Only

All Plastic Wing Nuts

Thread Size	Wingspan	Hex Size	Washer Diameter	Overall height
10-24	1.24"	.375"	.63"	.53"
1/4-20	1.24"	.375"	.63"	.53"



Molded Nylon Threads

Knob Style	1/4-20	5/16-18
T1D	✓	✓

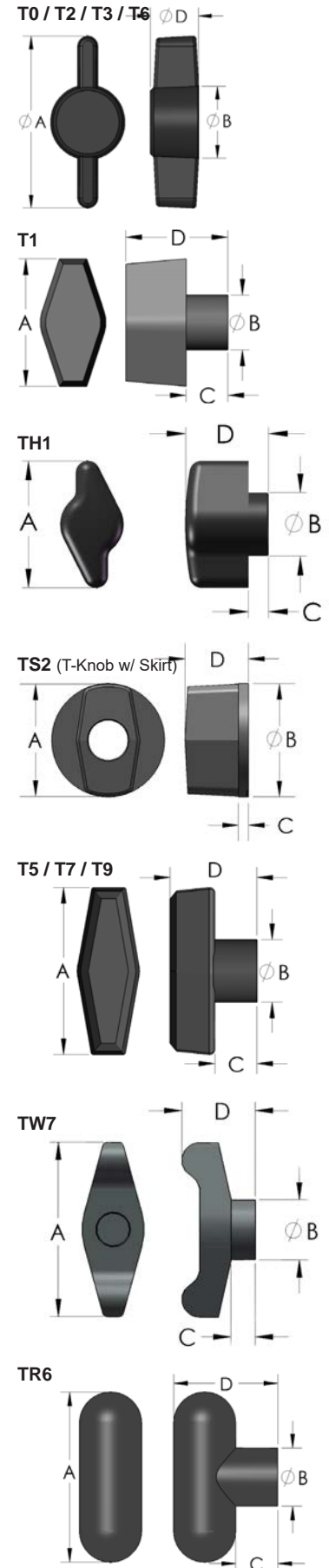
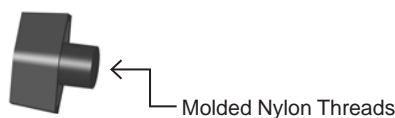

Knurled Knobs

Knob Style	A	B	C	D
K1•	.63"	.50"	.17"	.36"
K7	.75"	.50"	.28"	.50"
K7A	.75"	.50"	.38"	.62"
K7B	.75"	.50"	.18"	.38"
K7C	.75"	.30"	.40"	.61"
K3•	.75"	.50"	.17"	.48"
K3A•	.75"	.50"	.52"	.81"
K6•	1.00"	.63"	.09"	.50"
K6A•	1.00"	.63"	.12"	.53"
K6C•	1.00"	.63"	.40"	.81"
K6D•	1.00"	.63"	.17"	.58"
HT2•	.75"	.50"	.40"	.75"

- Can Only be Made Blind
- Can Only be Made with a Stud
- * Dimension "C" may be changed upon request. Engineering charges may apply to certain sizes.

Male & Female Insert Sizes Available

Knob Style	#8	#10	1/4	5/16	3/8
	M4	M5	M6	M8	M10
K1	✓	✓	✓		
K7	✓	✓	✓		
K7A	✓	✓	✓		
K7B	✓	✓	✓		
K7C	✓	✓	✓		
HT2	✓	✓	✓		
K3	✓	✓	✓	✓	
K3A	✓	✓	✓	✓	
K6	✓	✓	✓	✓	✓
K6A	✓	✓	✓	✓	✓
K6C	✓	✓	✓	✓	✓
K6D	✓	✓	✓	✓	✓
K6 w/ Exposed Phillips Drive	✓	✓	✓	✓	

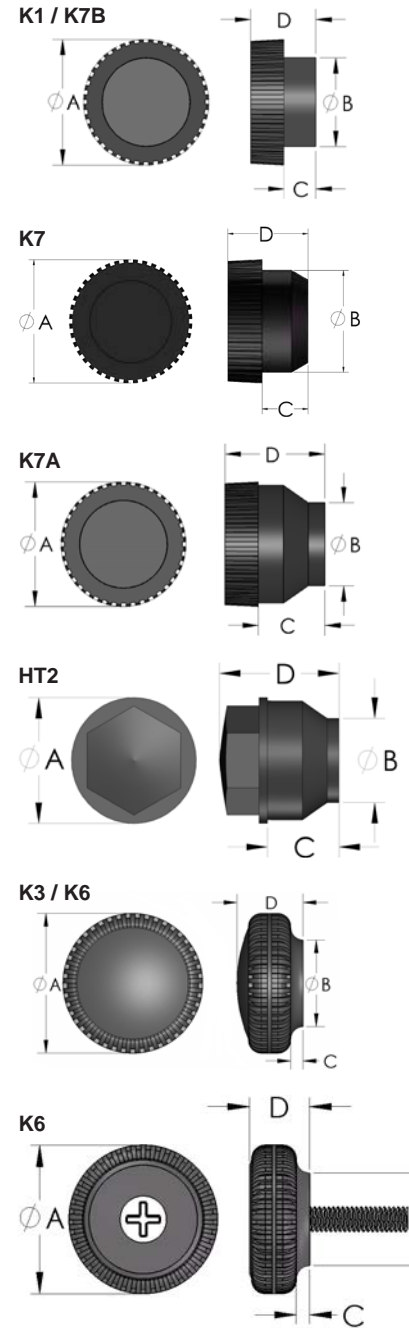

* Phillips or Hex Drive also available in K1 or K7 styles.

Snap-Lock Knobs

Snap-Lock Knobs allow users to assemble their own knobs with the nuts or bolts of their choice.

The knobs are molded with a hex hole of the appropriate size to accept standard hex nuts, locknuts, hex bolts, and hex cap screws. Fasteners can easily be pushed into position and snapped into the hex hole for a secure fit. This unique design is perfect for MRO, prototypes, jigs and fixtures, and unusual length fasteners. Snap-Lock Star Knobs are available in imperial thread sizes matching 1/4", 5/16", & 3/8" as well as Metric sizes M6, M8, & M10. Snap-Lock knobs in the 3-Prong and T-Knob styles are only available with a 1/4" hex. Nuts and bolts are also stock items.

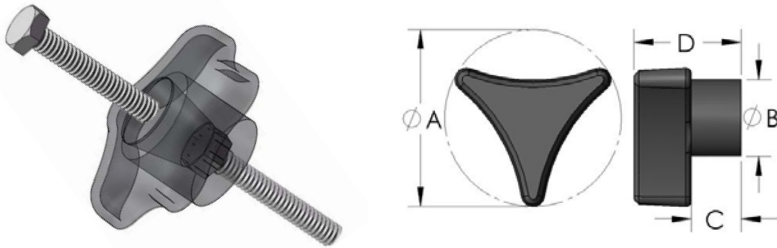

Hardware drops in (inserted on an angle) and snaps into hex hole.

Knob Style	A	B	C	D
3P4 (3-Arm)	1.75"	.75"	.49"	1.06"
4P4 (4-Arm)	1.75"	.75"	.54"	1.04"
4P7 (4-Arm)	2.49"	.98"	.36"	1.00"
5S2 (5-Arm)	1.30"	.85"	.70"	1.15"
5S3 (5-Arm)	1.75"	.88"	.75"	1.25"
5SA (5-Arm)	2.25"	.99"	.47"	.98"
F2 (Fluted Knob)	1.38"	.98"	.17"	.59"
F4 (Fluted Knob)	1.75"	1.25"	.28"	.86"
F6 (Fluted Knob)	2.38"	1.25"	.62"	1.23"
RT5 (3-Arm)	2.02"	.75"	.49"	1.09"
TH1 (T-Knob)	1.26"	.63"	.20"	.83"
T5 (T-Knob)	2.00"	.75"	.49"	1.06"

Hex Hole Sizes

Knob Style	#10	1/4	5/16	3/8	1/2
		M6	M8	M10	M12
4P7				✓	✓
5S2	✓	✓	✓		
5S3/5SA		✓	✓	✓	
F2	✓	✓			
F4			✓	✓	
F6		✓	✓	✓	✓
3P4	✓	✓	✓■		
4P4	✓	✓			
RT5		✓	✓		
TH1	✓	✓			
T5		✓	✓		

■ Only Accepts 5/16

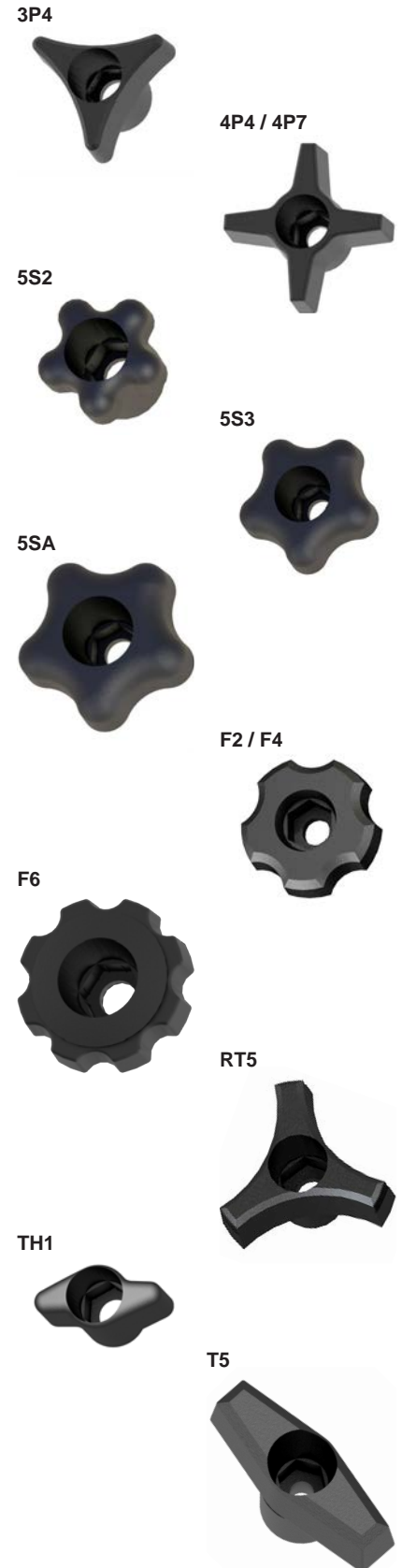

Press-On Thumb Screws

Snaps onto a Socket Head Cap Screw

Knob Style	A	B	C	D
N1	.312"	.19"	.28"	.13"
N2	.375"	.23"	.36"	.17"
N3	.50"	.25"	.41"	.18"
N4	.625"	.25"	.42"	.17"
N5	.75"	.31"	.50"	.17"
N6	1.00"	.41"	.59"	.27"
K3	.75"	.50"	.17"	.48"
K6	1.00"	.63"	.09"	.50"

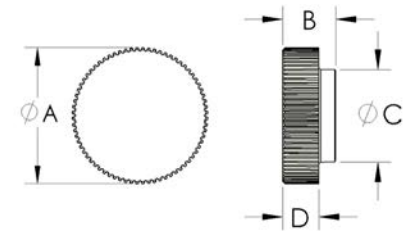

N1 / N2 / N3 / N4 / N5 / N6

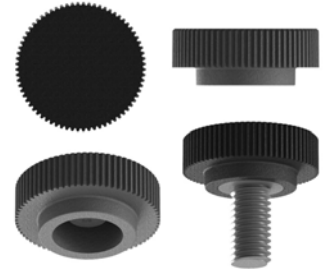

K3 / K6



Press-On Knobs Using Socket Head Cap Screw

Thread Diameters Available

Knob Style	#4	#6	#8	#10	1/4	5/16	M4	M5	M6	M8
N1	✓	✓								
N2		✓	✓							
N3			✓	✓			✓			
N4			✓	✓				✓		
N5				✓	✓				✓	
N6				✓	✓	✓		✓	✓	✓
K3			✓	✓	✓		✓	✓		
K6					✓	✓			✓	✓

Female Press-On Knobs Using Female Bushings

Knob Style	4-40	6-32	8-32	#10	1/4-20	5/16-18
			M4 x .07	M5 x .08	M6 x 1	M8 x 1.25
N1	✓					
N2		✓				
N3			✓			
N4				✓		
N5					✓	
N6					✓	✓

Female Press-On Knobs



Press-On Thumb Screws

Snaps onto a Socket Head Cap Screw

T0 / T2 / T3 / T6

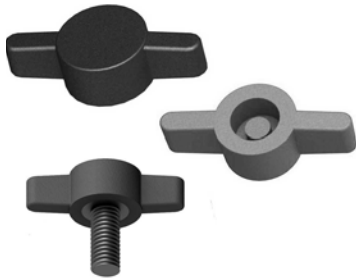

TH1



RT2



O3



Knob Style	A	B	C	D
T0	1.02"	.48"	--	.26"
T2	1.25"	.24"	--	.35"
T3	1.50"	.63"	--	.41"
T6	1.75"	.80"	--	.50"
TH1	1.26"	.63"	.20"	.83"
RT2	.75"	.50"	.23"	.51"
O3	1.50"	.375"	.78"	.475"

* Knobs are stocked in Black. Additional Standard Colors Include: Red, Yellow, Grey and Natural. Custom colors can be produced upon request.

Assemble Socket Head Cap Screw To:

Knob Style	#8	#10	1/4	5/16	3/8	M5	M6	M8	M10
T0	✓	✓							
T2		✓	✓						
T3			✓	✓			✓	✓	
T6					✓				
TH1			✓	✓			✓	✓	
RT2		✓	✓			✓	✓		
O3			✓	✓	✓		✓	✓	✓

Knurled Knob with Key Drive

Knob Style	A	B	C	D
N1	.312"	.19"	.28"	.13"
N2	.375"	.23"	.36"	.17"
N3	.50"	.25"	.41"	.18"
N4	.625"	.25"	.42"	.17"
N5	.75"	.31"	.50"	.17"
N6	1.00"	.41"	.59"	.27"

* Due to an insert bury of either 3/32" or 1/8", actual stud lengths may vary slightly.

N1 - N6



Knob Style	#4	#6	#8	#10	1/4"	5/16"
N1	✓					
N2		✓				
N3			✓			
N4				✓		
N5					✓	
N6					✓	✓

Universal Knobs - Ball / Tapered

Ball Style

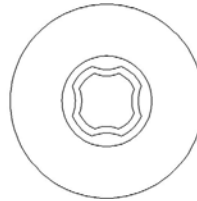
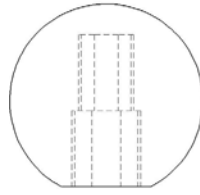
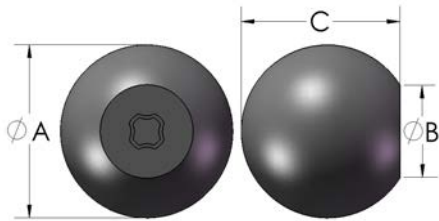

Tapered Style

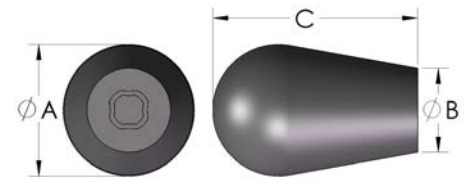

One Knob Fits Multiple Thread Sizes

- Self-Tapping/Threading
- Vibration Resistant - No Need for Glue
- Reduce SKU's
- No Metal Insert—Will Not Rust
- High Impact Polypropylene
- Available in Polypropylene and Soft Touch TPE Material

Knob Style	A	B	C
B3U	1.375"	.75"	1.24"
B4U	1.50"	.75"	1.38"
B4SU	1.50"	.75"	1.38"
B5U	1.63"	.75"	1.50"
B5SU	1.63"	.75"	1.50"
B7U	1.88"	1.00"	1.75"
B7SU	1.88"	1.00"	1.75"
S3U	1.38"	.92"	2.00"
S3SU	1.38"	.92"	2.00"
S5U	1.63"	1.00"	2.42" (ref)
S5SU	1.63"	1.00"	2.42" (ref)

■ Available in Soft Touch TPE Material - The "S" in Knob Style Denotes Soft Touch TPE Material.
 * Dimension "C" may be changed upon request. Engineering charges may apply to certain sizes.

Female Sizes Available

Accepts Course & Fine Threads

Knob Style	#8	#10	1/4	5/16	3/8	M5	M6
B3U	✓	✓				✓	
B4U		✓	✓			✓	
B4SU	✓	✓					✓
B5U			✓	✓		✓	
B5SU		✓	✓				✓
B7U				✓	✓	✓	
B7SU			✓	✓			✓
S3U	✓	✓	✓	✓		✓	
S5U			✓	✓		✓	
S5SU			✓	✓			✓

■ 1/4 & 5/16 molded into same knob; 3/8 & 1/2 molded into same knob.
 * No Metric equivalent for 1/2 thread diameter.

Press Fit Ball Knobs

Knobs press onto unthreaded shaft. The knobs maintain a firm grip due to a combination of compression, friction and an internal feature that allows the air to be evacuated from the hole to create a vacuum.

Ball Knobs

Knob Style	A	B	C
B1	1.00"	.62"	.88"
B2	1.25"	.62"	1.15"
B3	1.38"	.75"	1.28"
B4	1.47"	.75"	1.40"
B5	1.61"	.75"	1.52"
B7	1.88"	1.00"	1.75"

Available in Soft Touch TPE Material

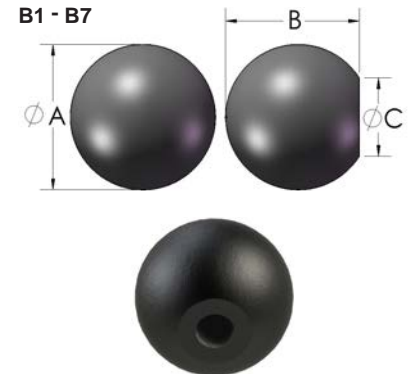

Tapered Knobs

Knob Style	A	B	C
SD	1.125	.56"	1.44"
S3	1.38"	.92"	2.00"
S5	1.60"	1.00"	2.42" (ref)
L2	1.11"	.76"	3.85"
LF2	1.11"	.76"	3.30"

Available in Soft Touch TPE Material

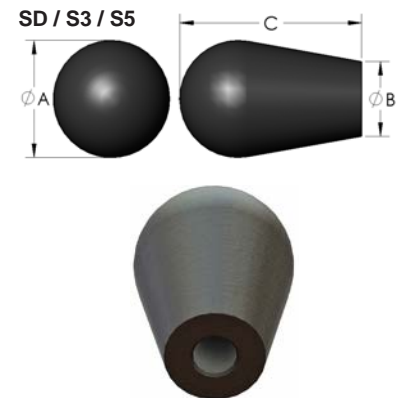

Male & Female Insert Sizes Available

Knob Style	1/4	5/16	3/8	1/2	5/8	3/4
B1	✓	✓				
B2	✓	✓	✓			
B3	✓	✓	✓	✓		
B4 / B5	✓	✓	✓	✓	✓	
B7	✓	✓	✓	✓	✓	✓
SD / S3	✓	✓	✓	✓		
S5	✓	✓	✓	✓	✓	✓
L2 / LF2	✓	✓	✓	✓		

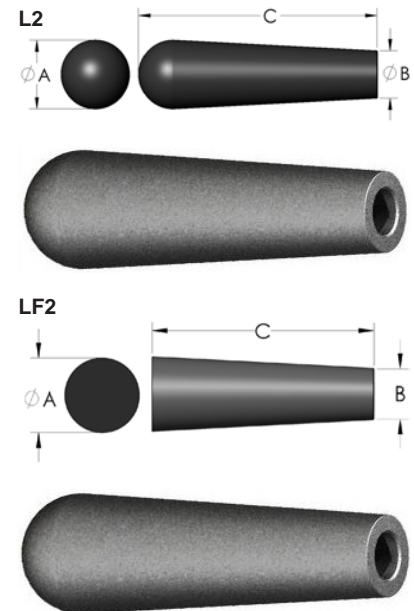

Metal Knurled Knobs

Knob Style	A	B	C	D
KF1 / KC1	.75"	.50"	.25"	.375"
KF2 / KC2	1.00"	.625"	.25"	.50"
KF3 / KC3	1.375"	.625"	.375"	.50"
KF4 / KC4	1.50"	.75"	.312"	.687"
KF5 / KC5	1.875"	.75"	.375"	.50"
KF6 / KC6	2.00"	1.00"	.375"	.75"
KF7 / KC7	2.25"	1.125"	.50"	1.00"
KF8 / KC8	2.50"	1.50"	.562"	.937"

KF1 - KF8 (Fine Knurls)

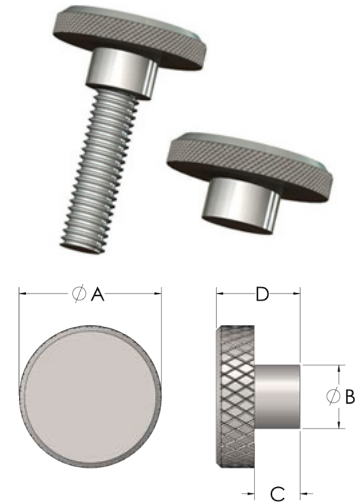

KC1 - KC8 (Course Knurls)



- * Dimension "B & C" may be changed upon request.
- * Fine Knurls - 33 Pitch; Coarse Knurls - 14 Pitch

Male & Female Insert Sizes Available

Knob Style	#8	#10	1/4	5/16	3/8	7/16	1/2
	M4	M5	M6	M8	M10	M12	M14
KF1 / KC1	✓	✓	✓	✓			
KF2 / KC2 / KF3 / KC3	✓	✓	✓	✓	✓		
KF4 / KC4 / KF5 / KC5	✓	✓	✓	✓	✓	✓	
KF6 / KC6 / KF7 / KC7 / KF8 / KC8	✓	✓	✓	✓	✓	✓	✓

Quick Release Knobs

Used on Fast, Rapid Adjustments

Quick release knobs are used in such applications where the knob has to be completely removed after the releasing operation and refitted very rapidly for re-clamping. For starters, the knob is tilted over the top of the threaded spindle. The knob can then be adjusted rapidly to the position necessary. When in position, the knob is tilted upright into a straight position for engaging of the threads on knob and spindle. The knob will then have to be turned only by a fraction to achieve clamping.

4P7

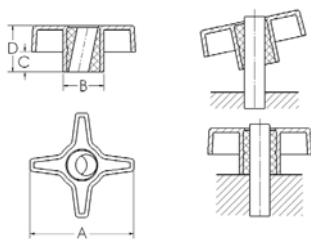

F6

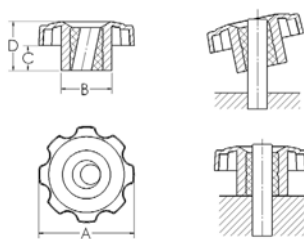

5SA

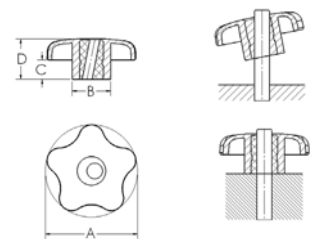

Knob Style	A	B	C	D
4P7	2.46"	.98"	.48"	1.13"
F6	2.38"	1.25"	.62"	1.23"
5SA	2.27"	.98"	.47"	1.00"

Female Insert Sizes Available

Knob Style	1/4-20	5/16-18	3/8-16	1/2-13
4P7 / F6	✓	✓	✓	✓
5SA	✓	✓		

Control Knobs

Most Control Knobs Can Be Customized with Aluminum Inlays, Top / Side Indicator Lines, Pad Printed Letters / Numbers, Decals and More

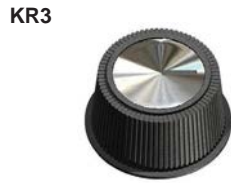

RK1 / RK2 / RK3 / RK4 / RK5



RA4

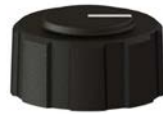

FK3

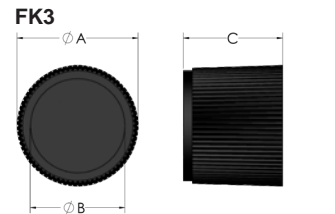
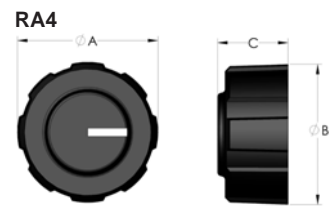
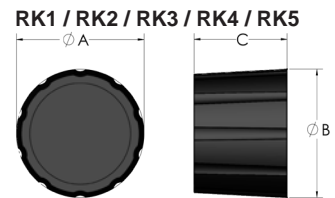
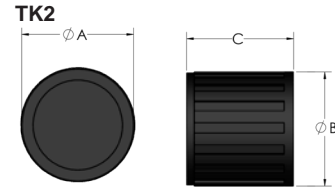
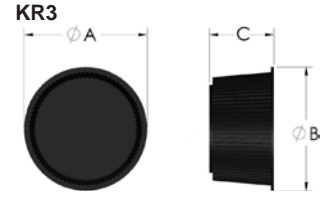
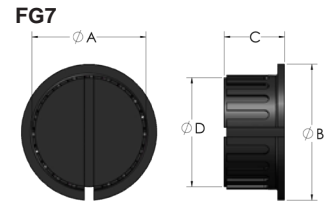

Knob Style	A	B	C	D
FG7	1.32"	1.57"	.74"	.75"
KR3	1.00"	1.20"	.63"	.75"
TK2	.529"	.54"	.506"	.75"
RK1	.39"	.52"	.66"	.75"
RK2	.59"	.71"	.66"	.93"
RK3	.83"	.90"	.66"	1.22"
RK4	1.11"	1.19"	.66"	1.16"
RK5	1.79"	1.86"	.66"	1.70"
RA4	1.00"	.50"	--	--
FK3	.80"	.66"	.69"	--

Pointer Knobs

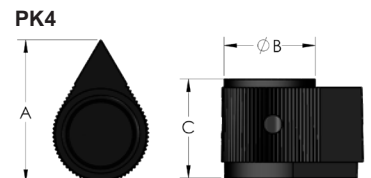
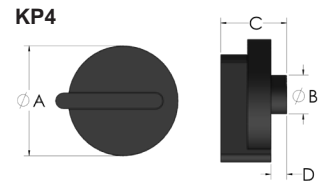

Knob Style	A	B	C	D
KP4	1.95"	.259"	1.05"	.25"
PK4	1.05"	.675"	.73"	--

Pad Printing & Laser Etching

Customize Your Knob by Using Our In-House Pad Printing & Decorating Capabilities



Custom Molding

Custom Molding & Knob Modifications Available Upon Request

Raised Lettering



Internal Phillips Drive



Two Tone



Internal Hex Drive

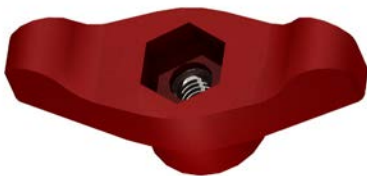

External Hex Drive



Custom Molded Part



Custom Molded Part



Custom Molded Part



Custom Molded Part



QUICK RELEASE HARDWARE

- 23** Ring Detent Pins
- 25** Threaded Detent Pins
- 26** Clevis Pins
- 26** Adjustable Clevis Pins
- 26** Cotterless Clevis Pins
- 27** Hitch Pins
- 28** Wire Lock Pins
- 29** Lynch Pins
- 29** Ring Pins
- 30** Knob Detent Pins
- 31** Magnetic Selector Pins
- 31** Swell Action Latch

A large, bold, yellow number '2' is positioned on the right side of the page. It is a simple, sans-serif font with a slight curve at the top and bottom.

Ring Detent Pins

Pin Diameter	Ball Diameter
3/16"	3/32"
1/4"	1/8"
5/16"	5/32"
3/8"	3/16"
7/16"	7/32"
1/2"	1/4"

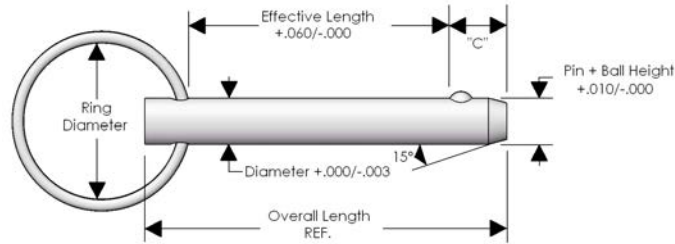

Steel , Zinc Part Number	Stainless Part Number	Nominal Diameter	Effective Length	Ball Position "C"	Overall Length	Pin & Ball Height	Ring O.D.
RD3160500-21	RD3160500-70	3/16"	1/2"	.200"	.887"	.204"	1.00"
RD3160750-21	RD3160750-70	3/16"	3/4"	.200"	1.137"	.204"	1.00"
RD3161000-21	RD3161000-70	3/16"	1"	.200"	1.387"	.204"	1.00"
RD3161250-21	RD3161250-70	3/16"	1-1/4"	.200"	1.637"	.204"	1.00"
RD3161500-21	RD3161500-70	3/16"	1-1/2"	.200"	1.887"	.204"	1.00"
RD3162000-21	RD3162000-70	3/16"	2"	.200"	2.387"	.204"	1.00"
RD3162500-21	RD3162500-70	3/16"	2-1/2"	.200"	2.887"	.204"	1.00"
RD3163000-21	RD3163000-70	3/16"	3"	.200"	3.387"	.204"	1.00"
RD4X0500-21	RD4X0500-70	1/4"	1/2"	.312"	1.062"	.286"	1.00"
RD4X0750-21	RD4X0750-70	1/4"	3/4"	.312"	1.312"	.286"	1.00"
RD4X1000-21	RD4X1000-70	1/4"	1"	.312"	1.562"	.286"	1.00"
RD4X1250-21	RD4X1250-70	1/4"	1-1/4"	.312"	1.812"	.286"	1.00"
RD4X1500-21	RD4X1500-70	1/4"	1-1/2"	.312"	2.062"	.286"	1.00"
RD4X1750-21	RD4X1750-70	1/4"	1-3/4"	.312"	2.312"	.286"	1.00"
RD4X2000-21	RD4X2000-70	1/4"	2"	.312"	2.562"	.286"	1.00"
RD4X2250-21	RD4X2250-70	1/4"	2-1/4"	.312"	2.812"	.286"	1.00"
RD4X2500-21	RD4X2500-70	1/4"	2-1/2"	.312"	3.062"	.286"	1.00"
RD4X2750-21	RD4X2750-70	1/4"	2-3/4"	.312"	3.312"	.286"	1.00"
RD4X3000-21	RD4X3000-70	1/4"	3"	.312"	3.562"	.286"	1.00"
RD5X0750-21	RD5X0750-70	5/16"	3/4"	.375"	1.375"	.358"	1.00"
RD5X1000-21	RD5X1000-70	5/16"	1"	.375"	1.625"	.358"	1.00"
RD5X1250-21	RD5X1250-70	5/16"	1-1/4"	.375"	1.875"	.358"	1.00"
RD5X1500-21	RD5X1500-70	5/16"	1-1/2"	.375"	2.125"	.358"	1.00"
RD5X1750-21	RD5X1750-70	5/16"	1-3/4"	.375"	2.375"	.358"	1.00"
RD5X2000-21	RD5X2000-70	5/16"	2"	.375"	2.625"	.358"	1.00"
RD5X2250-21	RD5X2250-70	5/16"	2-1/4"	.375"	2.875"	.358"	1.00"
RD5X2500-21	RD5X2500-70	5/16"	2-1/2"	.375"	3.125"	.358"	1.00"
RD5X2750-21	RD5X2750-70	5/16"	2-3/4"	.375"	3.375"	.358"	1.00"
RD5X3000-21	RD5X3000-70	5/16"	3"	.375"	3.625"	.358"	1.00"
RD6X0750-21	RD6X0750-70	3/8"	3/4"	.375"	1.375"	.426"	1.00"
RD6X1000-21	RD6X1000-70	3/8"	1"	.375"	1.625"	.426"	1.00"

Ring Detent Pins

Pin Diameter	Ball Diameter
3/16"	3/32"
1/4"	1/8"
5/16"	5/32"
3/8"	3/16"
7/16"	7/32"
1/2"	1/4"

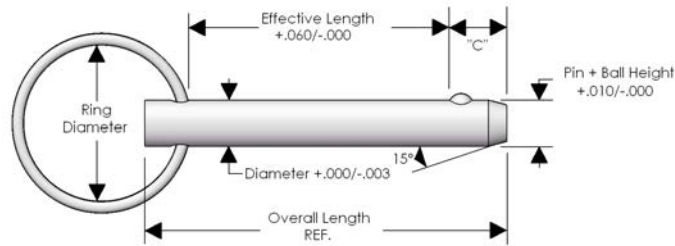

Steel , Zinc Part Number	Stainless Part Number	Nominal Diameter	Effective Length	Ball Position "C"	Overall Length	Pin & Ball Height	Ring O.D.
RD6X1500-21	RD6X1500-70	3/8"	1-1/2"	.375"	2.125"	.426"	1.00"
RD6X2000-21	RD6X2000-70	3/8"	2"	.375"	2.625"	.426"	1.00"
RD6X2500-21	RD6X2500-70	3/8"	2-1/2"	.375"	3.125"	.426"	1.00"
RD6X3000-21	RD6X3000-70	3/8"	3"	.375"	3.625"	.426"	1.00"
RD6X3500-21	RD6X3500-70	3/8"	3-1/2"	.375"	4.125"	.426"	1.00"
RD6X4000-21	RD6X4000-70	3/8"	4"	.375"	4.625"	.426"	1.00"
RD6X4500-21	RD6X4500-70	3/8"	4-1/2"	.375"	5.125"	.426"	1.00"
RD6X5000-21	RD6X5000-70	3/8"	5"	.375"	5.625"	.426"	1.38"
RD7X1000-21	RD7X1000-70	7/16"	1"	.500"	1.750"	.489"	1.38"
RD7X2000-21	RD7X2000-70	7/16"	2"	.500"	2.750"	.489"	1.38"
RD7X3000-21	RD7X3000-70	7/16"	3"	.500"	3.750"	.489"	1.38"
RD8X1000-21	RD8X1000-70	1/2"	1"	.625"	1.750"	.570"	1.38"
RD8X1500-21	RD8X1500-70	1/2"	1-1/2"	.625"	2.250"	.570"	1.38"
RD8X2000-21	RD8X2000-70	1/2"	2"	.625"	2.750"	.570"	1.38"
RD8X2500-21	RD8X2500-70	1/2"	2-1/2"	.625"	3.250"	.570"	1.38"
RD8X3000-21	RD8X3000-70	1/2"	3"	.625"	3.750"	.570"	1.38"
RD8X3500-21	RD8X3500-70	1/2"	3-1/2"	.625"	4.250"	.570"	1.38"
RD8X4000-21	RD8X4000-70	1/2"	4"	.625"	4.750"	.570"	1.38"
RD8X4500-21	RD8X4500-70	1/2"	4-1/2"	.625"	5.250"	.570"	1.38"
RD8X5000-21	RD8X5000-70	1/2"	5"	.625"	5.750"	.570"	1.38"
RD8X5500-21	RD8X5500-70	1/2"	5-1/2"	.625"	6.250"	.570"	1.38"
RD8X6000-21	RD8X6000-70	1/2"	6"	.625"	6.750"	.570"	1.38"

Large Diameters: Available in custom lengths for 5/8", 3/4", and 1" diameter pins.

Custom Lengths & Designs: Available Upon Request

Metric Sizes: Available upon request

Threaded Detent Pins

Pin Diameter	Ball Diameter
1/4"	1/8"
5/16"	5/32"
3/8"	3/16"
1/2"	1/4"

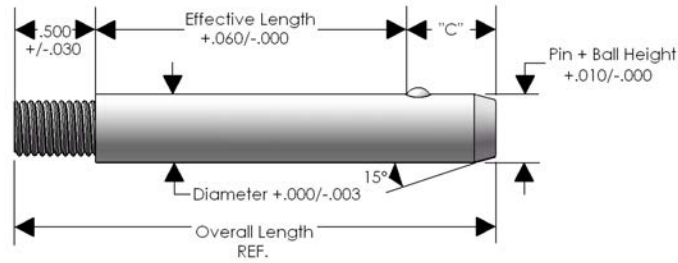

Pin: 12L14 or 1008/1018, Zinc
Ball: 18-8 Stainless Steel

Steel , Zinc Part Number	Nominal Diameter	Effective Length	Ball Position "C"	Overall Length	Pin & Ball Height	Ring O.D.
TD4C1000-21	1/4"	1"	.250"	1.750"	.286"	1/4-20 UNC 2A
TD4C1500-21	1/4"	1-1/2"	.250"	2.250"	.286"	1/4-20 UNC 2A
TD4C1750-21	1/4"	1-3/4"	.250"	2.500"	.286"	1/4-20 UNC 2A
TD4C2000-21	1/4"	2"	.250"	2.750"	.286"	1/4-20 UNC 2A
TD4C2500-21	1/4"	2-1/2"	.250"	3.250"	.286"	1/4-20 UNC 2A
TD4C2750-21	1/4"	2-3/4"	.250"	3.500"	.286"	1/4-20 UNC 2A
TD4C3000-21	1/4"	3"	.250"	3.750"	.286"	1/4-20 UNC 2A
TD4C3750-21	1/4"	3-3/4"	.250"	4.500"	.286"	1/4-20 UNC 2A
TD4C4000-21	1/4"	4"	.250"	4.750"	.286"	1/4-20 UNC 2A
TD5C2750-21	5/16"	2-3/4"	.375"	3.500"	.358"	5/16-18 UNC 2A
TD5C3000-21	5/16"	3"	.375"	3.750"	.358"	5/16-18 UNC 2A
TD6C1000-21	3/8"	1"	.375"	1.850"	.426"	3/8-16 UNC 2A
TD6C1500-21	3/8"	1-1/2"	.375"	2.375"	.426"	3/8-16 UNC 2A
TD6C2000-21	3/8"	2"	.375"	2.875"	.426"	3/8-16 UNC 2A
TD6C2125-21	3/8"	2-1/8"	.375"	3.000"	.426"	3/8-16 UNC 2A
TD6C2500-21	3/8"	2-1/2"	.375"	3.375"	.426"	3/8-16 UNC 2A
TD6C3000-21	3/8"	3"	.375"	3.875"	.426"	3/8-16 UNC 2A
TD6C3125-21	3/8"	3-1/8"	.375"	4.000"	.426"	3/8-16 UNC 2A
TD8C2500-21	1/2"	2-1/2"	.500"	3.500"	.570"	3/8-16 UNC 2A
TD8C3250-21	1/2"	3-1/4"	.500"	4.250"	.570"	3/8-16 UNC 2A
TD8C3500-21	1/2"	3-1/2"	.500"	4.500"	.570"	3/8-16 UNC 2A

Clevis / Adjustable / Cotterless Clevis Pins

Clevis Pin

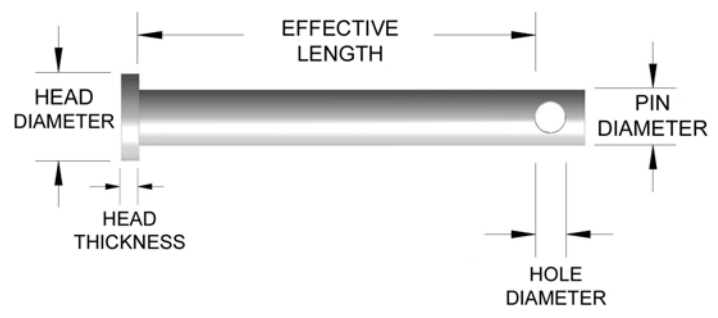

Adjustable Clevis Pin

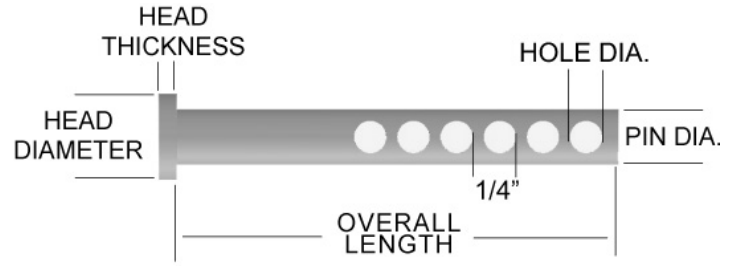

Cotterless Clevis Pin

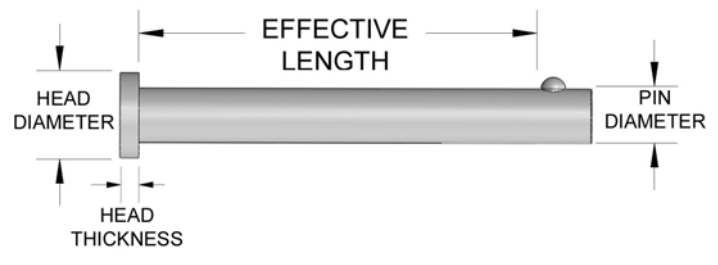

Nominal Pin Diameter	Hole Diameter (Clevis / Adjustable)	Head Diameter	Head Thickness
3/16" (#10)	3/32"	.320"/.302"	.070"/.052"
1/4"	3/32"	.380"/.365"	.100"/.084"
5/16"	9/64"	.440"/.428"	.100"/.084"
3/8"	5/32"	.510"/.490"	.130"/.115"
7/16"	5/32"	.570"/.552"	.160"/.146"
1/2"	5/32"	.630"/.615"	.160"/.146"
5/8"	5/32"	.820"/.802"	.210"/.193"
3/4"	3/16"	.940"/.928"	.260"/.240"

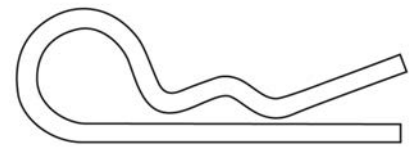

Hair Pin
Clevis / Adjustable Clevis Mating Part

* Other diameters available upon request. Minimums apply.

Pin Diameter	Grip Length / Effective Length (Inches)																		
	0.50"	0.75"	1.00"	1.25"	1.50"	1.75"	2.00"	2.25"	2.50"	2.75"	3.00"	3.25"	3.50"	4.00"	4.50"	5.00"	5.50"	6.00"	
3/16" (#10)	✓	✓	✓	✓	✓	✓	✓	✓	✓	✓	✓	✓	✓	✓	✓	✓	✓	✓	✓
1/4"	✓	✓	✓	✓	✓	✓	✓	✓	✓	✓	✓	✓	✓	✓	✓	✓	✓	✓	✓
5/16"	✓	✓	✓	✓	✓	✓	✓	✓	✓	✓	✓	✓	✓	✓	✓	✓	✓	✓	✓
3/8"	✓	✓	✓	✓	✓	✓	✓	✓	✓	✓	✓	✓	✓	✓	✓	✓	✓	✓	✓
7/16"	✓	✓	✓	✓	✓	✓	✓	✓	✓	✓	✓	✓	✓	✓	✓	✓	✓	✓	✓
1/2"	✓	✓	✓	✓	✓	✓	✓	✓	✓	✓	✓	✓	✓	✓	✓	✓	✓	✓	✓
5/8"	✓	✓	✓	✓	✓	✓	✓	✓	✓	✓	✓	✓	✓	✓	✓	✓	✓	✓	✓
3/4"	✓	✓	✓	✓	✓	✓	✓	✓	✓	✓	✓	✓	✓	✓	✓	✓	✓	✓	✓

* Other effective lengths available upon request. Minimums apply.

Hitch Pins

Nominal Pin Diameter	Hole Diameter	Collar Diameter
3/8"	5/32"	.69"
1/2"	13/64"	.91"
5/8"	13/64"	1.08"
3/4"	13/64"	1.27"
7/8"	13/64"	1.45"
1"	13/64"	1.64"
1-1/8"	1/4"	1.81"
1-1/4"	1/4"	1.86"
1-3/8"	1/4"	2.50"
1-1/2"	1/4"	2.50"

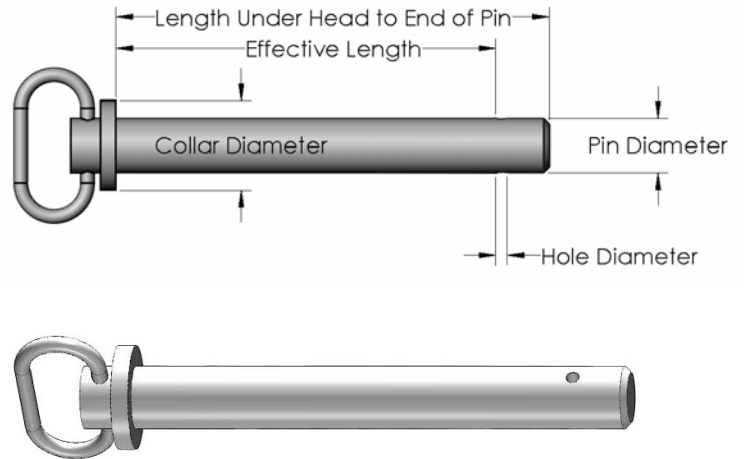

* Other diameters available upon request. Minimums apply.

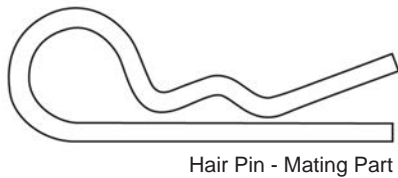

Pin Diameter	Overall Length (Inches)											
	2.50"	3.00"	3.50"	3.63"	3.75"	4.00"	4.25"	4.50"	4.75"	5.00"	5.25"	5.50"
3/8"	✓	✓	✓			✓		✓		✓		✓
1/2"			✓	✓	✓	✓	✓	✓	✓	✓	✓	✓
5/8"						✓	✓	✓	✓	✓	✓	✓
3/4"						✓	✓	✓	✓	✓	✓	✓
7/8"						✓		✓		✓		✓
1"								✓	✓	✓		✓

Pin Diameter	Overall Length (Inches)										
	5.75"	6.00"	6.25"	6.50"	6.75"	7.00"	7.50"	8.00"	8.50"	12.00"	13.00"
3/8"		✓									
1/2"		✓									
5/8"		✓	✓	✓	✓						
3/4"	✓	✓		✓	✓						
7/8"		✓		✓		✓					
1"		✓		✓	✓	✓	✓			✓	
1-1/8"						✓			✓	✓	
1-1/4"						✓			✓	✓	
1-3/8"						✓	✓	✓			
1-1/2"								✓	✓		✓

* Other effective lengths available upon request. Minimums apply.

Wire Lock Pins

- Perfect for "Quick-Release" Applications
- Pin & Cotter Combination in a Single, Dependable Assembly
- Wire Loop Snaps Over the Pin to Lock it in Place
- Fast & Easy Removal
- Manufactured From a Cold Formed 1010 Steel Pin and a Spring Wire Loop
- Standard Finish is Zinc with Yellow Dichromate for Corrosion Resistance

Round

Size & Style	A	B	C	D
1/4" X 1-3/4"	.238" .250"	1.75"	2.50"	.090" .094"
1/4" X 2-5/16"	.238" .250"	2.312"	2.875"	.090" .094"
5/16" X 2-3/8"	.300" .312"	2.38"	3.00"	.090" .094"
3/8" X 2-1/4"	.363" .375"	2.25"	3.125"	.090" .094"

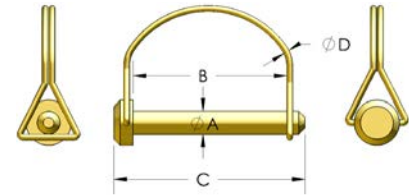

Square

Size & Style	A	B	C	D
1/4" X 2-1/4"	.238" .250"	2.25"	3.20"	.090" .094"
5/16" X 2-3/8"	.300" .312"	2.38"	3.00"	.090" .094"
3/8" X 2-1/4"	.363" .375"	2.25"	3.125"	.090" .094"

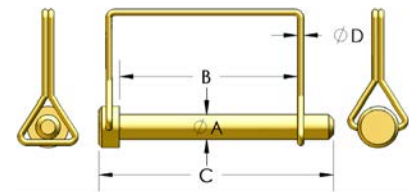

Wire Lock Pins - Tab Style

Round

Size & Style	A	B	C	D
1/4" X 1-3/4"	.238" .250"	1.75"	2.50"	.090" .094"

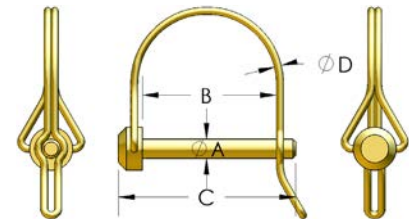

Square

Size & Style	A	B	C	D
1/4" X 2-1/4"	.238" .250"	2.25"	3.20"	.090" .094"
5/16" X 2-3/8"	.300" .312"	2.38"	3.00"	.090" .094"
3/8" X 2-1/4"	.363" .375"	2.25"	3.125"	.090" .094"

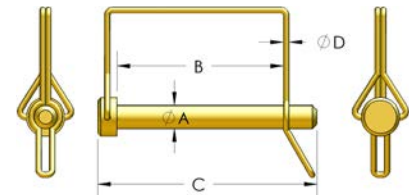

Lynch Pins

- Perfect for "Quick-Release" Applications
- Self-Locking Ring Snaps into Place to Securely Hold the Assembly
- Quick Removal
- Forged for Maximum Strength
- Standard Finish is Zinc with Yellow Dichromate for Corrosion Resistance
- All Dimensions are Normal

Pin Diameter	A (+/- 1/8")	B (+/- 1/8")	C (+/- 1/8")	D (+/- 1/64")
3/16" (.181"-.186")	1-1/8"	1-27/64"	1-3/4"	1/8"
1/4" (.243"-.248")	1-7/16"	1-3/4"	2-1/8"	7/64"
5/16" (.306"-.311")	1-1/2"	1-25/32"	2-5/32"	1/8"
7/16" (.431"-.436")	1-15/32"	1-3/4"	2-7/32"	5/32"
7/16" (.431"-.436")	1-19/32"	2"	2-1/2"	11/64"

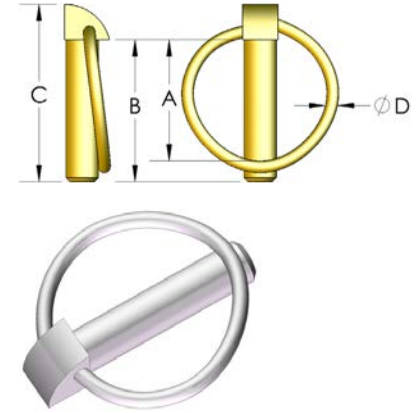

Ring Pins

Nominal Pin Diameter	Hole Diameter	Ring O.D.
3/16" (#10)	3/32"	7/8"
1/4"	3/32"	1"
5/16"	1/8"	1"
3/8"	9/64"	1"
7/16"	5/32"	1"
1/2"	5/32"	1-1/4"
5/8"	5/32"	1-1/4"
3/4"	3/16"	1-1/2"

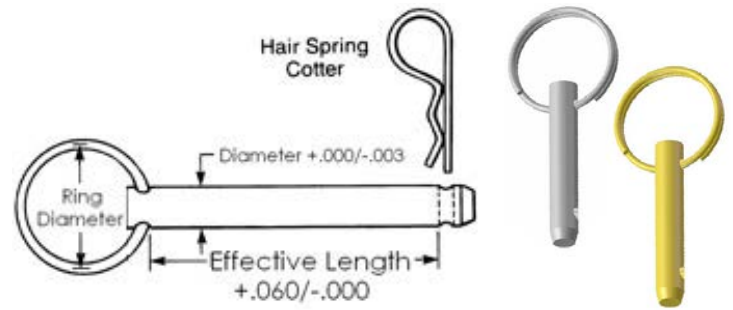

* Other diameters available upon request. Minimums apply.

Pin Diameter	Grip Length (Inches)																		
	0.50"	0.75"	1.00"	1.25"	1.50"	1.75"	2.00"	2.25"	2.50"	2.75"	3.00"	3.25"	3.50"	4.00"	4.50"	5.00"	5.50"	6.00"	
3/16 (#10)	✓	✓	✓	✓	✓	✓	✓	✓	✓	✓	✓	✓	✓	✓	✓	✓	✓	✓	✓
1/4	✓	✓	✓	✓	✓	✓	✓	✓	✓	✓	✓	✓	✓	✓	✓	✓	✓	✓	✓
5/16	✓	✓	✓	✓	✓	✓	✓	✓	✓	✓	✓	✓	✓	✓	✓	✓	✓	✓	✓
3/8	✓	✓	✓	✓	✓	✓	✓	✓	✓	✓	✓	✓	✓	✓	✓	✓	✓	✓	✓
7/16	✓	✓	✓	✓	✓	✓	✓	✓	✓	✓	✓	✓	✓	✓	✓	✓	✓	✓	✓
1/2	✓	✓	✓	✓	✓	✓	✓	✓	✓	✓	✓	✓	✓	✓	✓	✓	✓	✓	✓
5/8	✓	✓	✓	✓	✓	✓	✓	✓	✓	✓	✓	✓	✓	✓	✓	✓	✓	✓	✓
3/4	✓	✓	✓	✓	✓	✓	✓	✓	✓	✓	✓	✓	✓	✓	✓	✓	✓	✓	✓

* Other effective lengths available upon request. Minimums apply.

Knob Detent Pins



Nominal Diameter	Effective Length	Ball Position	Overall Length	Pin + Ball Height
1/4"	1"	.25"	1.75"	.286"
1/4"	1-1/2"	.25"	2.25"	.286"
1/4"	1-3/4"	.25"	2.50"	.286"
1/4"	2"	.25"	2.75"	.286"
1/4"	2-1/2"	.25"	3.25"	.286"
1/4"	2-3/4"	.25"	3.50"	.286"
1/4"	3"	.25"	3.75"	.286"
1/4"	3-3/4"	.25"	4.50"	.286"
1/4"	4"	.25"	4.75"	.286"
5/16"	2-3/4"	.25"	3.50"	.358"
5/16"	3"	.25"	3.75"	.358"
3/8"	1"	.375"	1.875"	.426"
3/8"	1-1/2"	.375"	2.375"	.426"
3/8"	2"	.375"	2.875"	.426"
3/8"	2-1/8"	.375"	3.00"	.426"
3/8"	2-1/2"	.375"	3.375"	.426"
3/8"	3"	.375"	3.875"	.426"
3/8"	3-1/8"	.375"	4.00"	.426"
1/2"	2-1/2"	.50"	3.50"	.57"
1/2"	3-1/4"	.50"	4.25"	.57"
1/2"	3-1/2"	.50"	4.50"	.57"

* Knob Available in Soft Touch TPE Material

Magnetic Selector Pins



- **Knobs:** Wide variety of sizes, shapes & colors.
 - **Pins:** Medium Carbon Steel, Zinc Plate
 - **Coiled Lanyards:** Standard & Heavy Duty with variety of terminal options.
 - **Magnet:** Embedded inside of knob.
 - Custom Assemblies per your specification
- * Knob Available in Soft Touch TPE Material

Swell Action Latch

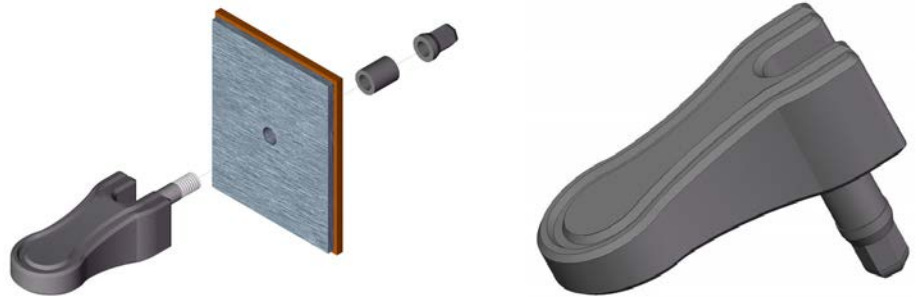
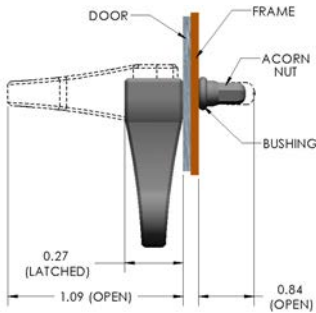

Handle Material	Nut Material	Nut Size	Stud Material & Finish	Stud Thread	Bushing Material
Nylon 66 Black (Colors on Request)	Nylon 66 Black	8-32 .25" Across Flats .46" Tall	Zinc Diecast Black Chromate	8-32 w/ Flats for Hole Alignment	SBR Rubber Black

Low Profile - Access Panels, Doors, etc.

- Latch & Handle in One Assembly
- Accommodates Misalignment Between Frame & Door
- Accepts Frame Thickness up to 1/8"
- Excellent for Blind Applications
- Wide Variety of Frame Materials
 - Metal
 - Glass
 - Plastic
- Reversible

SPRING LOADED PINS

- 33** T-Handle Positive Locking Pins
- 34** Button Handle Positive Locking Pins
- 35** L-Handle Positive Locking Pins
- 36** Ring Handle Positive Locking Pins
- 37** Positive Locking Pin Specs
- 38** Pin Receptacles
- 39** Pop Pins
- 40** Pull Ring Plunger Pins
- 40** T-Handle Retractable Plunger Pins
- 41** Short Pull Ring Plunger Pins
- 42** Plastic Knob Plunger Pins
- 42** Euro-Style Indexing Plunger Pin
- 43** Knurled Knob Retractable Plunger Pins
- 44** Lever Style Plunger Pins
- 45** Short Lever Style Plunger Pins



T-Handle Positive Locking Pins

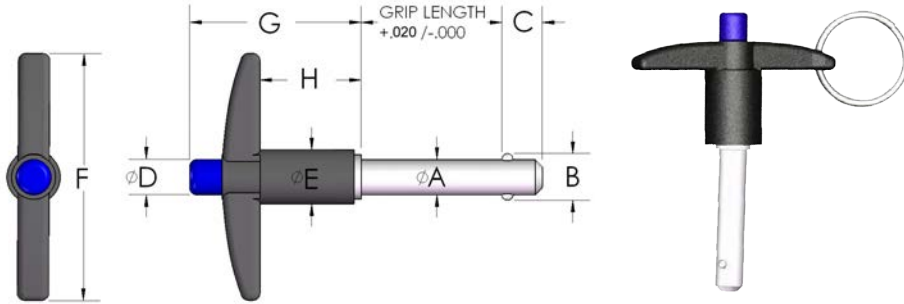

- Available in Steel or Stainless Steel Body
- Handle is Black Cast Aluminum and the Button is Blue Anodized Aluminum
- Includes Hole and Ring for Easy Attachment of Optional Wire Lanyard

Nominal Pin Diameter	A		B	C	D	E	F	G	H
	Min.	Max.	+/- .005"	+ .000" / - .040"					
3/16" (#10)	.1870"	.1885"	.220"	.260"	1/4"	1/2"	1-13/16"	1-1/4"	3/4"
1/4"	.2470"	.2485"	.289"	.290"	1/4"	1/2"	1-13/16"	1-1/4"	3/4"
5/16"	.3095"	.3110"	.375"	.330"	1/4"	1/2"	1-13/16"	1-1/4"	3/4"
3/8"	.3720"	.3735"	.440"	.365"	5/16"	19/32"	2"	1-7/16"	15/16"
7/16"	.4345"	.4360"	.509"	.380"	5/16"	19/32"	2"	1-7/16"	15/16"
1/2"	.4970"	.4985"	.594"	.460"	15/32"	3/4"	2"	1-5/8"	1"
9/16"	.5595"	.5610"	.666"	.510"	15/32"	3/4"	2-3/8"	1-5/8"	1"
5/8"	.6220"	.6235"	.750"	.580"	9/16"	15/16"	3-1/8"	1-31/32"	1-3/16"
3/4"	.7470"	.7485"	.887"	.670"	5/8"	15/16"	3-1/8"	1-31/32"	1-3/16"
7/8"	.8720"	.8735"	1.046"	.760"	3/4"	1-1/4"	3-1/2"	2-1/4"	1-11/32"
1"	.9970"	.9985"	1.209"	.890"	3/4"	1-1/4"	3-1/2"	2-1/4"	1-11/32"

Pin Diameter	Grip Length (Inches)											
	0.50"	0.75"	1.00"	1.25"	1.50"	1.75"	2.00"	2.50"	3.00"	4.00"	5.00"	6.00"
3/16" (#10)	✓	✓	✓	✓	✓	✓	✓	✓	✓	✓	✓	✓
1/4"	✓	✓	✓	✓	✓	✓	✓	✓	✓	✓	✓	✓
5/16"	✓	✓	✓	✓	✓	✓	✓	✓	✓	✓	✓	✓
3/8"	✓	✓	✓	✓	✓	✓	✓	✓	✓	✓	✓	✓
7/16"	✓	✓	✓	✓	✓	✓	✓	✓	✓	✓	✓	✓
1/2"	✓	✓	✓	✓	✓	✓	✓	✓	✓	✓	✓	✓
9/16"	✓	✓	✓	✓	✓	✓	✓	✓	✓	✓	✓	✓
5/8"	✓	✓	✓	✓	✓	✓	✓	✓	✓	✓	✓	✓
3/4"	✓	✓	✓	✓	✓	✓	✓	✓	✓	✓	✓	✓
7/8"	✓	✓	✓	✓	✓	✓	✓	✓	✓	✓	✓	✓
1"	✓	✓	✓	✓	✓	✓	✓	✓	✓	✓	✓	✓

* See Page 36 For Additional Pin Specifications.

Button Handle Positive Locking Pins

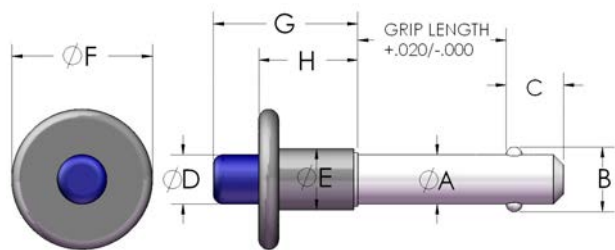

- Available in Steel or Stainless Steel Body
- Handle is Black Cast Aluminum and the Button is Blue Anodized Aluminum
- Includes Hole and Ring for Easy Attachment of Optional Wire Lanyard

Nominal Pin Diameter	A		B +/- .005"	C + .000" / - .040"	D	E	F	G	H
	Min.	Max.							
3/16" (#10)	.1870"	.1885"	.220"	.260"	1/4"	7/16"	13/16"	13/16"	5/8"
1/4"	.2470"	.2485"	.289"	.290"	1/4"	7/16"	13/16"	7/8"	5/8"
5/16"	.3095"	.3110"	.375"	.330"	1/4"	7/16"	7/8"	29/32"	5/8"
3/8"	.3720"	.3735"	.440"	.365"	5/16"	9/16"	1-1/8"	1-1/32"	3/4"
7/16"	.4345"	.4360"	.509"	.380"	5/16"	9/16"	1-1/8"	1-3/32"	3/4"
1/2"	.4970"	.4985"	.594"	.460"	7/16"	23/32"	1-3/8"	1-3/16"	13/16"
9/16"	.5595"	.5610"	.666"	.510"	7/16"	23/32"	1-3/8"	1-3/8"	1"
5/8"	.6220"	.6235"	.750"	.580"	37/64"	27/32"	1-5/8"	1-1/2"	1-1/16"
3/4"	.7470"	.7485"	.887"	.670"	37/64"	15/16"	1-7/8"	1-21/32"	1-5/32"
7/8"	.8720"	.8735"	1.046"	.760"	3/4"	1-1/8"	2-3/16"	1-31/32"	1-1/2"
1"	.9970"	.9985"	1.219"	.890"	3/4"	1-3/16"	2-3/16"	2-1/8"	1-1/2"

Pin Diameter	Grip Length (Inches)											
	0.50"	0.75"	1.00"	1.25"	1.50"	1.75"	2.00"	2.50"	3.00"	4.00"	5.00"	6.00"
3/16 (#10)	✓	✓	✓	✓	✓	✓	✓	✓	✓	✓	✓	✓
1/4	✓	✓	✓	✓	✓	✓	✓	✓	✓	✓	✓	✓
5/16	✓	✓	✓	✓	✓	✓	✓	✓	✓	✓	✓	✓
3/8	✓	✓	✓	✓	✓	✓	✓	✓	✓	✓	✓	✓
7/16	✓	✓	✓	✓	✓	✓	✓	✓	✓	✓	✓	✓
1/2	✓	✓	✓	✓	✓	✓	✓	✓	✓	✓	✓	✓
9/16	✓	✓	✓	✓	✓	✓	✓	✓	✓	✓	✓	✓
5/8	✓	✓	✓	✓	✓	✓	✓	✓	✓	✓	✓	✓
3/4	✓	✓	✓	✓	✓	✓	✓	✓	✓	✓	✓	✓
7/8	✓	✓	✓	✓	✓	✓	✓	✓	✓	✓	✓	✓
1	✓	✓	✓	✓	✓	✓	✓	✓	✓	✓	✓	✓

* See Page 36 For Additional Pin Specifications.

L-Handle Positive Locking Pins

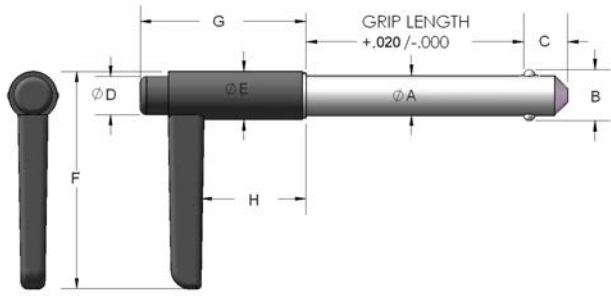

- Available in Steel or Stainless Steel Body
- Handle is Black Cast Aluminum and the Button is Blue Anodized Aluminum
- Includes Hole and Ring for Easy Attachment of Optional Wire Lanyard

Nominal Pin Diameter	A		B +/-0.005"	C +0.000"/-0.040"	D	E	F	G	H
	Min.	Max.							
3/16" (#10)	.1870"	.1885"	.220"	.260"	1/4"	1/2"	1-3/4"	1-1/4"	3/4"
1/4"	.2470"	.2485"	.289"	.290"	1/4"	1/2"	1-3/4"	1-1/4"	3/4"
5/16"	.3095"	.3110"	.375"	.330"	1/4"	1/2"	1-3/4"	1-1/4"	3/4"
3/8"	.3720"	.3735"	.440"	.365"	5/16"	19/32"	2"	1-7/16"	15/16"
7/16"	.4345"	.4360"	.509"	.380"	5/16"	19/32"	2"	1-7/16"	15/16"
1/2"	.4970"	.4985"	.594"	.460"	15/32"	3/4"	2-1/4"	1-5/8"	1"
9/16"	.5595"	.5610"	.666"	.510"	15/32"	3/4"	2-1/4"	1-5/8"	1"
5/8"	.6220"	.6235"	.750"	.580"	9/16"	15/16"	2-1/2"	1-31/32"	1-3/16"
3/4"	.7470"	.7485"	.887"	.670"	5/8"	15/16"	2-1/2"	1-31/32"	1-3/16"
7/8"	.8720"	.8735"	1.046"	.760"	3/4"	1-1/4"	3-1/4"	2-1/4"	1-11/32"
1"	.9970"	.9985"	1.219"	.890"	3/4"	1-1/4"	3-1/4"	2-1/4"	1-11/32"

Pin Diameter	Grip Length (Inches)											
	0.50"	0.75"	1.00"	1.25"	1.50"	1.75"	2.00"	2.50"	3.00"	4.00"	5.00"	6.00"
3/16" (#10)	✓	✓	✓	✓	✓	✓	✓	✓	✓	✓	✓	✓
1/4"	✓	✓	✓	✓	✓	✓	✓	✓	✓	✓	✓	✓
5/16"	✓	✓	✓	✓	✓	✓	✓	✓	✓	✓	✓	✓
3/8"	✓	✓	✓	✓	✓	✓	✓	✓	✓	✓	✓	✓
7/16"	✓	✓	✓	✓	✓	✓	✓	✓	✓	✓	✓	✓
1/2"	✓	✓	✓	✓	✓	✓	✓	✓	✓	✓	✓	✓
9/16"	✓	✓	✓	✓	✓	✓	✓	✓	✓	✓	✓	✓
5/8"	✓	✓	✓	✓	✓	✓	✓	✓	✓	✓	✓	✓
3/4"	✓	✓	✓	✓	✓	✓	✓	✓	✓	✓	✓	✓
7/8"	✓	✓	✓	✓	✓	✓	✓	✓	✓	✓	✓	✓
1"	✓	✓	✓	✓	✓	✓	✓	✓	✓	✓	✓	✓

* See Page 36 For Additional Pin Specifications.

Ring Handle Positive Locking Pins

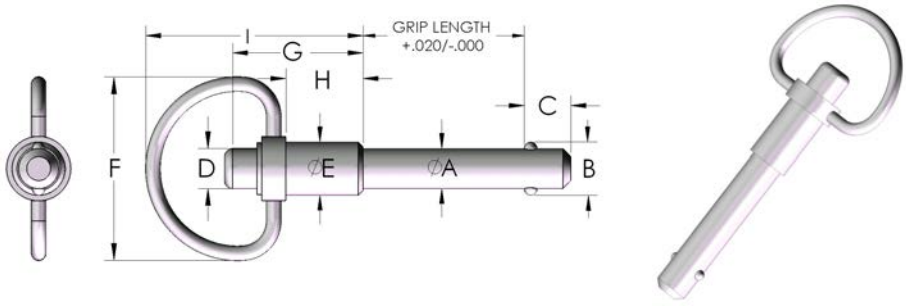

- Stainless Steel Handle with Stainless Button (stainless steel shank)
- Ring allows for Easy Attachment of Optional Wire Lanyard

Nominal Pin Diameter	A		B	C	D	E	F	G	H	I
	Min.	Max.	+/- .005"	+ .000"/- .040"						
3/16" (#10)	.1870"	.1885"	.220"	.260"	1/4"	7/16"	1-1/8"	13/16"	29/64"	1-11/32"
1/4"	.2470"	.2485"	.289"	.290"	1/4"	7/16"	1-1/8"	13/16"	29/64"	1-11/32"
5/16"	.3095"	.3110"	.375"	.330"	1/4"	7/16"	1-1/8"	27/32"	29/64"	1-11/32"
3/8"	.3720"	.3735"	.440"	.365"	5/16"	9/16"	1-1/8"	1"	19/32"	1-1/2"
7/16"	.4345"	.4360"	.509"	.380"	5/16"	9/16"	1-1/8"	1"	19/32"	1-1/2"
1/2"	.4970"	.4985"	.594"	.460"	7/16"	11/16"	1-3/8"	1-1/4"	5/8"	1-7/8"
9/16"	.5595"	.5610"	.666"	.510"	7/16"	11/16"	1-3/8"	1-1/4"	11/16"	1-7/8"
5/8"	.6220"	.6235"	.750"	.580"	1/2"	15/16"	1-5/8"	1-11/16"	7/8"	2-7/16"
3/4"	.7470"	.7485"	.887"	.670"	9/16"	15/16"	1-5/8"	1-13/16"	1-1/16"	2-7/16"
7/8"	.8720"	.8735"	1.046"	.760"	3/4"	1-3/16"	1-3/4"	2-3/16"	1-13/32"	2-29/32"
1"	.9970"	.9985"	1.219"	.890"	3/4"	1-3/16"	1-3/4"	2-1/8"	1-13/32"	2-29/32"

Pin Diameter	Grip Length (Inches)											
	0.50"	0.75"	1.00"	1.25"	1.50"	1.75"	2.00"	2.50"	3.00"	4.00"	5.00"	6.00"
3/16" (#10)	✓	✓	✓	✓	✓	✓	✓	✓	✓	✓	✓	✓
1/4"	✓	✓	✓	✓	✓	✓	✓	✓	✓	✓	✓	✓
5/16"	✓	✓	✓	✓	✓	✓	✓	✓	✓	✓	✓	✓
3/8"	✓	✓	✓	✓	✓	✓	✓	✓	✓	✓	✓	✓
7/16"	✓	✓	✓	✓	✓	✓	✓	✓	✓	✓	✓	✓
1/2"	✓	✓	✓	✓	✓	✓	✓	✓	✓	✓	✓	✓
9/16"	✓	✓	✓	✓	✓	✓	✓	✓	✓	✓	✓	✓
5/8"	✓	✓	✓	✓	✓	✓	✓	✓	✓	✓	✓	✓
3/4"	✓	✓	✓	✓	✓	✓	✓	✓	✓	✓	✓	✓
7/8"	✓	✓	✓	✓	✓	✓	✓	✓	✓	✓	✓	✓
1"	✓	✓	✓	✓	✓	✓	✓	✓	✓	✓	✓	✓

* See Page 36 For Additional Pin Specifications.

Positive Locking Pin Specs - All Styles



Part Description	Material
Body/Spindle	CRES 17-4/Alloy Steel 4130
Balls	CRES 440C
Button	Aluminum 2024
Button Handle	Aluminum 2024
Ring Handle	CRES 303/304
Recessed Button Handle	CRES 303/304
T-Handle	Aluminum, black
Collar	CRES 303/304

Pin Diameter	Double Shear Steel (In Pounds)	Double Shear Stainless Steel (In Pounds)	Tensile Minimum (In Pounds)	Hole Diameter Maximum	Hole Diameter Minimum
1/4"	8,200	9,200	230	.2540"	.2500"
5/16"	12,800	14,400	510	.3165"	.3125"
3/8"	18,400	20,600	575	.3790"	.3750"
7/16"	25,000	28,000	710	.4425"	.4375"
1/2"	32,800	36,800	1,160	.5050"	.5000"
9/16"	41,200	46,000	1,420	.5675"	.5625"
5/8"	51,200	57,500	2,070	.6300"	.6250"
3/4"	73,600	82,500	2,950	.7570"	.7500"
7/8"	100,000	112,500	3,900	.8820"	.8750"
1"	131,000	147,000	5,480	1.0100"	1.0000"

Pounds = Load Carrying Capabilities of the Pins

Pin Receptacles

Circle

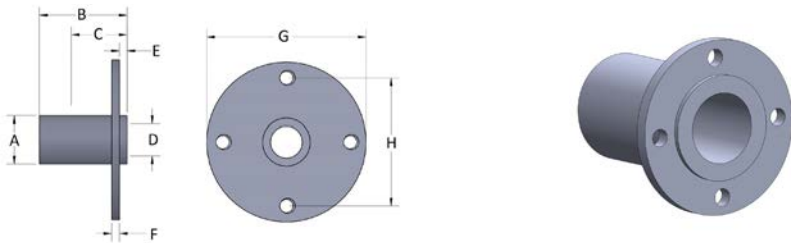

Diameter	A	B	C	D	E	F	G	H	Material
1/4"	3/8"	11/16"	3/8"	1/4"	.06"	.06"	1"	1-1/4"	Stainless Steel
5/16"	1/2"	3/4"	1/2"	5/16"	.06"	.06"	1"	1-1/4"	Stainless Steel
3/8"	9/16"	7/8"	9/16"	3/8"	.06"	.06"	1"	1-1/4"	Stainless Steel
1/2"	3/4"	1-3/16"	3/4"	1/2"	.06"	.06"	1-1/8"	1-1/2"	Stainless Steel

Diamond

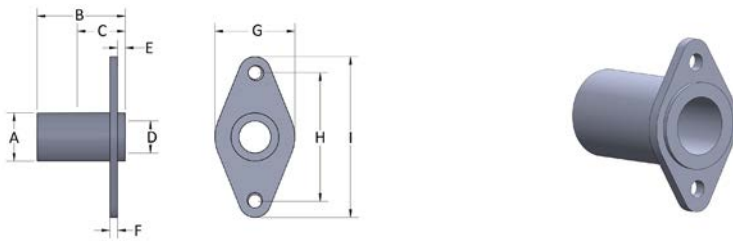

Diameter	A	B	C	D	E	F	G	H	I	Material
1/4"	3/8"	11/16"	3/8"	1/4"	.06"	.06"	5/8"	1"	1-1/4"	Stainless Steel
5/16"	1/2"	3/4"	1/2"	5/16"	.06"	.06"	5/8"	1"	1-1/4"	Stainless Steel
3/8"	9/16"	7/8"	9/16"	3/8"	.06"	.06"	5/8"	1"	1-1/4"	Stainless Steel
1/2"	3/4"	1-3/16"	3/4"	1/2"	.06"	.06"	7/8"	1-1/8"	1-1/2"	Stainless Steel

Oval

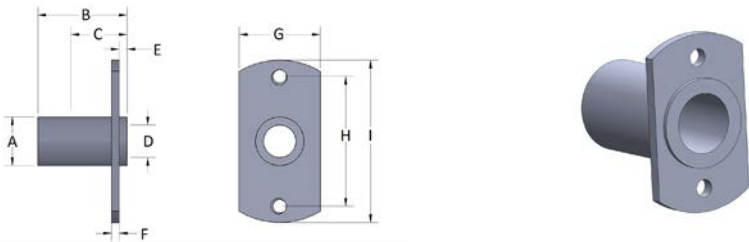

Diameter	A	B	C	D	E	F	G	H	I	Material
1/4"	3/8"	11/16"	3/8"	1/4"	.06"	.06"	5/8"	1"	1-1/4"	Stainless Steel
5/16"	1/2"	3/4"	1/2"	5/16"	.06"	.06"	5/8"	1"	1-1/4"	Stainless Steel
3/8"	9/16"	7/8"	9/16"	3/8"	.06"	.06"	5/8"	1"	1-1/4"	Stainless Steel
1/2"	3/4"	1-3/16"	3/4"	1/2"	.06"	.06"	7/8"	1-1/8"	1-1/2"	Stainless Steel

Pop Pins

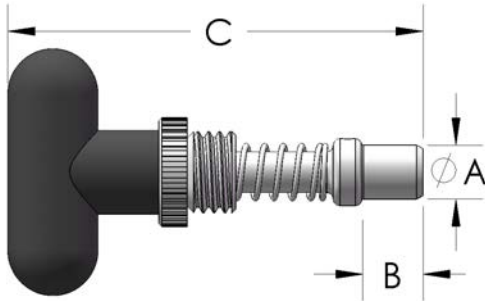

- Design for Quick Adjustments on Heavy Duty Applications
- Mates with a Weld-On Steel Barrel
- Pop-Cap Available in Course or Fine Thread
- Overall height Ranges from 3-5/8" to 5-1/16"
- Lock-Out Versions Available
- Custom Assemblies Per Your Specification

Pin Tip Style	A	B	C	Lock Out Option	Barrel Diameter	Barrel Height
5/16" Diameter Straight Tip	5/16"	.60"	Depending on Knob 3-9/16" to 3-13/16"	No (Upon request - Minimums apply.)	1.00"	1.50"
3/8" Diameter Straight Tip	3/8"	.60"	Depending on Knob 3-1/2" to 3-3/4"	Yes	1.00"	1.50"
1/2" Diameter Straight Tip ■	1/2"	.86"	Depending on Knob 3-1/2" to 4-1/16"	Yes	1.00"	1.50"
1/2" Diameter Straight Tip Long ■	1/2"	.86"	Depending on Knob 4-1/2" to 5-1/16"	No (Upon request - Minimums apply.)	1.00"	2.50" Long Barrel
1/2" Diameter Short Tip	1/2"	.56"	Depending on Knob 3-1/2" to 3-3/4"	Yes	1.00"	1.50"
1/2" Diameter Tapered Tip	1/2"	.61"	Depending on Knob 3-1/2" to 3-3/4"	No	1.00"	1.50"
Turn to Pull 3/8" Diameter Straight Tip	3/8"	.47"	3-11/16"	Twist to Pull Only - Type of Lock-Out	1.10"	.324"

- * Ball knobs are available in Soft Touch Material.
- All 1/2" diameter straight tip pop pins are designed to be used only in cases where the wall thickness of the material where the barrel is being welded is 9/32" or greater.

Pull Ring Plunger Pins

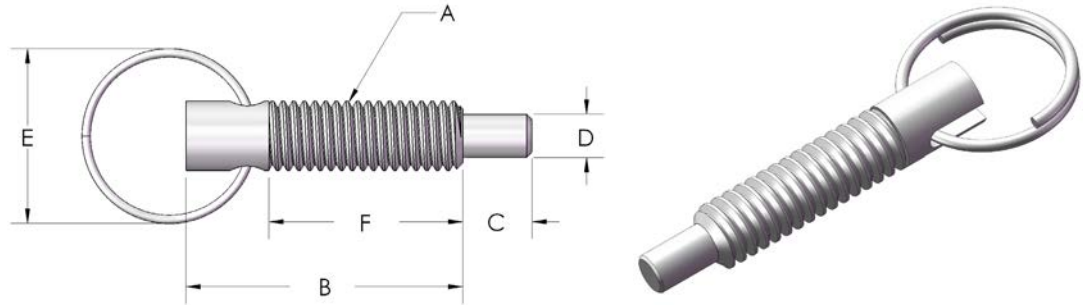

Pull Ring Plunger (Locking)

End Force (Lbs.)		A	B	C	D	E	F
Initial	Final	Threads					
1.00	2.50	1/4-20	1.14"	.250"	.155"	.62"	.80"
2.00	4.00	3/8-16	1.68"	.375"	.233"	.98"	1.20"
2.50	5.00	1/2-13	2.00"	.500"	.312"	1.26"	1.40"

- * Steel or Stainless versions available
- * Available with Anti-Vibration Locking Patch

T-Handle Retractable Plunger Pins

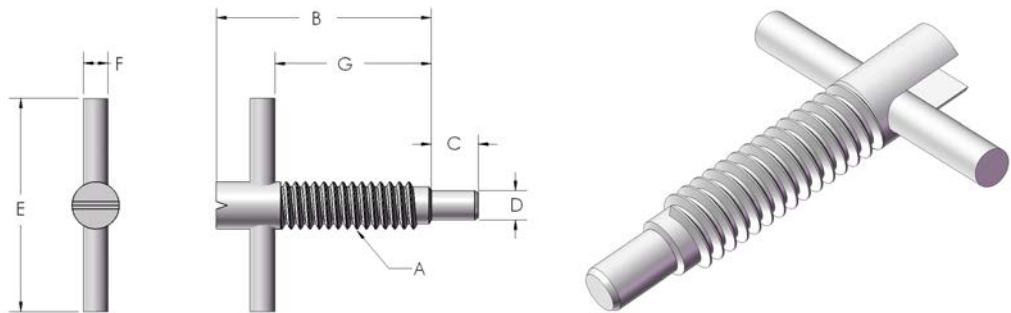

T-Handle Retractable Plunger Pins (Locking)

End Force (Lbs.)		A	B	C	D	E	F	G
Initial	Final	Threads						
1.00	2.50	1/4-20	1.14"	.25"	.155"	1.13"	.13"	.80"
2.00	4.00	3/8-16	1.68"	.375"	.233"	1.50"	.13"	1.20"
2.50	5.00	1/2-13	2.00"	.50"	.312"	2.00"	.16"	1.40"
2.50	5.00	5/8-11	2.38"	.625"	.375"	2.50"	.19"	1.70"

- * No Thread Relief for 1/4-20 Series
- * Available with Anti-Vibration Locking Patch

Short Pull Ring Plunger Pins

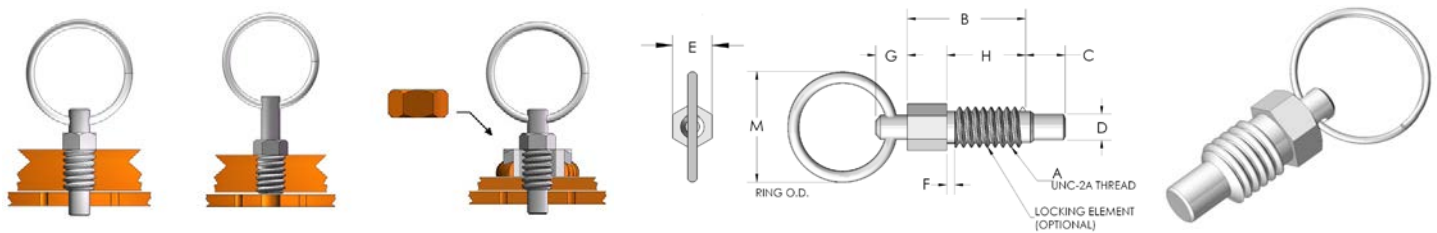

Pull Ring Plunger - Short Steel (Non-Locking)

End Force (Lbs.)		A	B	C	D	E	F	G	H	M
Initial	Final	Threads				Hex				
.50	2.00	1/4-20	.44"	.19"	.16"	.25"	■	.18"	.31"	.75"
.75	3.00	3/8-16	.63"	.28"	.25"	.38"	.13"	.19"	.44"	.75"
1.00	4.00	1/2-13	.81"	.38"	.31"	.50"	.13"	.25"	.56"	1.00"
1.25	5.00	5/8-11	1.00"	.44"	.38"	.62"	.13"	.31"	.69"	1.00"

- No Thread Relief for 1/4-20 Series
- * Available with Anti-Vibration Locking Patch

Pull Ring Plunger - Short Stainless Steel (Non-Locking)

End Force (Lbs.)		A	B	C	D	E	F	G	H	M
Initial	Final	Threads				Hex				
.50	2.00	1/4-20	.44"	.19"	.16"	.25"	■	.18"	.31"	.75"
.75	3.00	3/8-16	.63"	.28"	.25"	.38"	.13"	.19"	.44"	.75"
1.00	4.00	1/2-13	.81"	.38"	.31"	.50"	.13"	.25"	.56"	1.00"
1.25	5.00	5/8-11	1.00"	.44"	.38"	.62"	.13"	.31"	.69"	1.00"

- No Thread Relief for 1/4-20 Series
- * Available with Anti-Vibration Locking Patch

Plastic Knob Plunger Pins

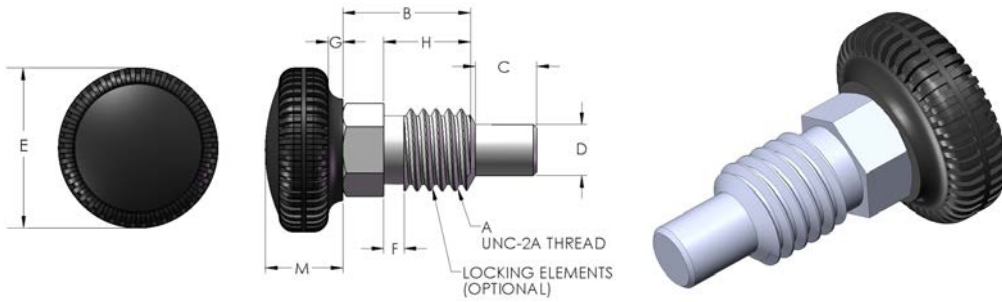

End Force (Lbs.)		A	B	C	D	E	F	G	H	M
Initial	Final	Threads				Knob Diameter		Hub Height		Knob Height
.50	2.00	1/4-20	.44"	.19"	.16"	.75"	■	.17"	.31"	.46"
.75	3.00	3/8-16	.63"	.28"	.25"	.75"	.13"	.17"	.44"	.46"
1.00	4.00	1/2-13	.81"	.38"	.31"	1.00"	.13"	.17"	.56"	.58"
1.25	5.00	5/8-11	1.00"	.44"	.38"	1.00"	.13"	.17"	.69"	.58"

- No Thread Relief for 1/4-20 Series
- * Available in Steel or Stainless Steel
- * Available with Anti-Vibration Locking Patch

Euro-Style Indexing Plunger Pin

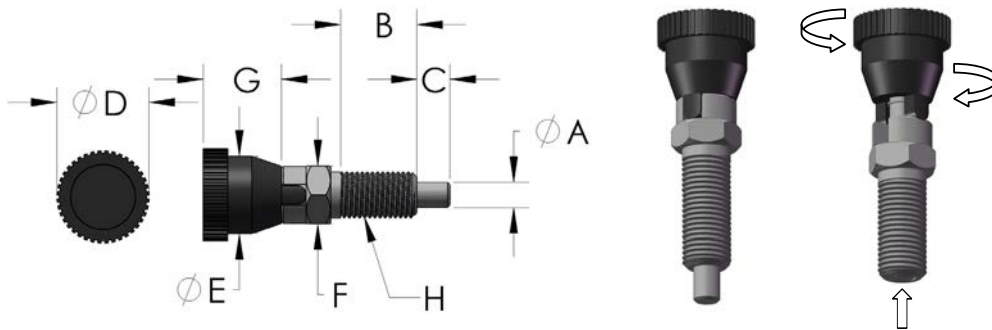

To lock-out pull up & twist knob 90° in either direction.

Threads	A	B	C	D	E	F	G	H
3/8-24	.20"	.67"	.20"	.75" (ref)	.63"	.47"	.30"	3/8-24
1/2-13	.23"	.78"	.23"	.98"	.57"	.55"	1.02"	1/2-13

Knurled Knob Retractable Plunger Pins

Lockout Plunger

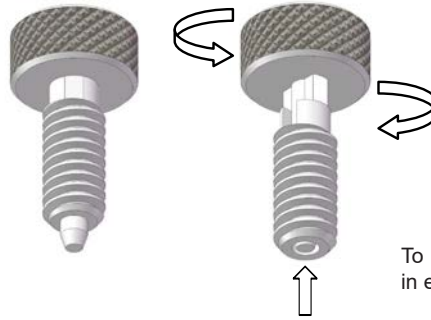
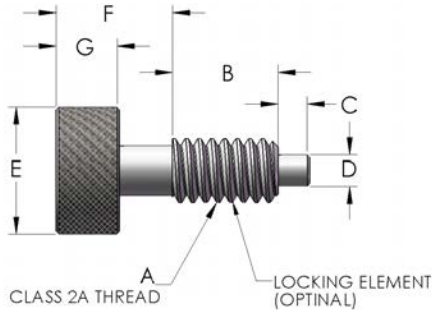

To lock-out pull up & twist knob 90° in either direction.

Knurled Knob Plunger Pin - Steel

End Force (Lbs.)		A	B	C	D°	E	F	G
Initial	Final	Threads						
.50	3.00	10-32	.40"	.094"	.104" ■	.38"	.25"	.19"
1.00	4.00	1/4-20	.50"	.125"	.123"	.50"	.313"	.019"
1.00	6.00	5/16-18	.625"	.188"	.154"	.63"	.375"	.25"
1.00	8.00	3/8-16	.75"	.218"	.185"	.75"	.50"	.31"
1.00	10.00	1/2-13	.875"	.25"	.248"	1.00"	.625"	.38"

- 10-32 Series has a radiused nose.
- Tolerance: +.001; -.0254 (+.000; -.001)
- * Available with Anti-Vibration Locking Patch

Knurled Knob Plunger Pin - Stainless Steel

End Force (Lbs.)		A	B	C	D°	E	F	G
Initial	Final	Threads						
.50	3.00	10-32	.40"	.094"	.104" ■	.38"	.25"	.19"
1.00	4.00	1/4-20	.50"	.125"	.123"	.50"	.313"	.019"
1.00	6.00	5/16-18	.625"	.188"	.154"	.63"	.375"	.25"
1.00	8.00	3/8-16	.75"	.218"	.185"	.75"	.50"	.31"
1.00	10.00	1/2-13	.875"	.25"	.248"	1.00"	.625"	.38"

- 10-32 Series has a radiused nose.
- *Tolerance: +.001; -.0254 (+.000; -.001)
- * Available with Anti-Vibration Locking Patch

Lever Style Plunger Pins

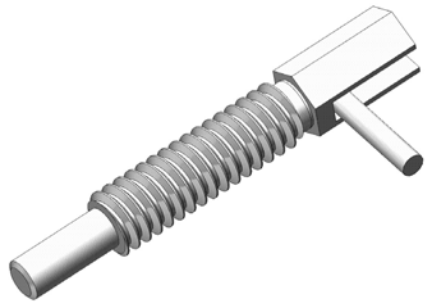
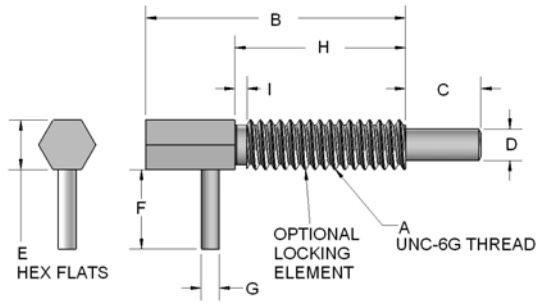

Locking

End Force (Lbs.)		A	B	C	D	E	F	G	H	I
Initial	Final	Threads				Hex				
.50	2.50	1/4-20	1.25"	.38"	.16"	.25"	.50"	.09"	.80"	■
.75	3.75	3/8-16	2.00"	.56"	.25"	.38"	.75"	.14"	1.31"	.13"
1.00	5.00	1/2-13	2.11"	.75"	.31"	.50"	.93"	.19"	1.25"	.15"
1.00	5.00	5/8-11	3.05"	1.00"	.38"	.62"	1.00"	.19"	2.00"	.18"

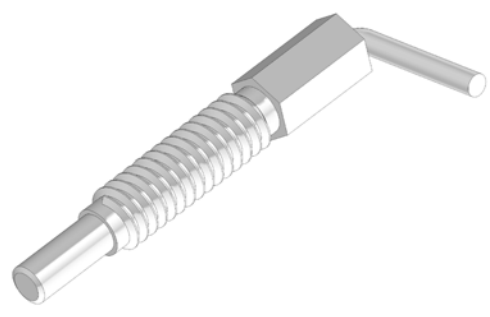
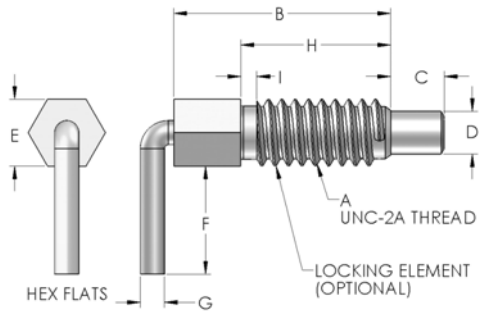

Non-Locking

End Force (Lbs.)		A	B	C	D	E	F	G	H	I
Initial	Final	Threads				Hex				
.50	2.50	1/4-20	1.25"	.38"	.16"	.25"	.50"	.09"	.80"	■
.75	3.75	3/8-16	2.00"	.56"	.25"	.38"	.75"	.14"	1.31"	.13"
1.00	5.00	1/2-13	2.11"	.75"	.31"	.50"	1.00"	.19"	1.25"	.15"
1.00	5.00	5/8-11	3.05"	1.00"	.38"	.62"	1.00"	.19"	2.00"	.18"

- No Thread Relief for 1/4-20 Series
- * Steel or Stainless Steel Versions Available
- * Available with Anti-Vibration Locking Patch

Short Lever Style Plunger Pins

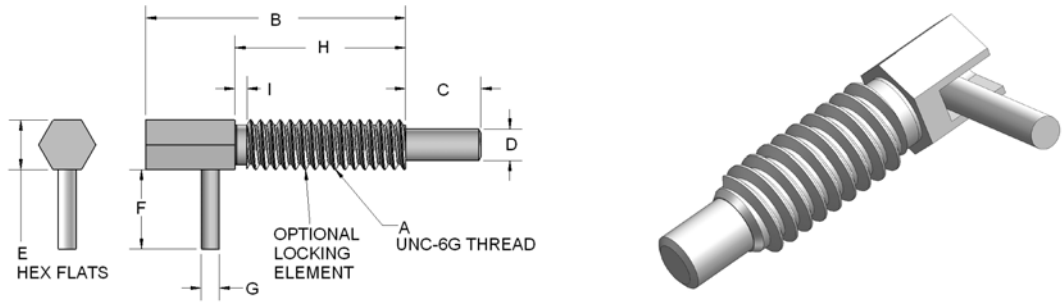

Locking

End Force (Lbs.)		A	B	C	D	E	F	G	H	I
Initial	Final	Threads				Hex				
.12	.50	1/4-20	.75"	.20"	.16"	.25"	.40"	.09"	.50"	■
.25	1.25	3/8-16	1.13"	.30"	.25"	.38"	.75"	.14"	.75"	.13"
.50	2.00	1/2-13	1.50"	.40"	.31"	.50"	.75"	.19"	1.00"	.15"
.75	2.50	5/8-11	1.88"	.50"	.38"	.62"	.88"	.19"	1.25"	.18"

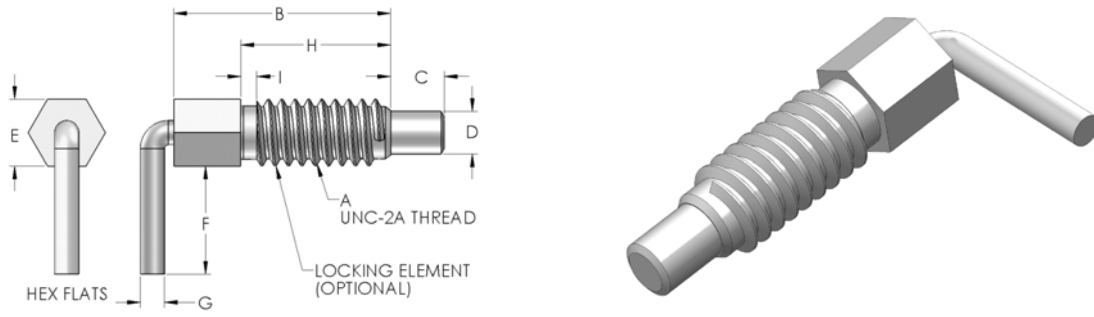

Non-Locking

End Force (Lbs.)		A	B	C	D	E	F	G	H	I
Initial	Final	Threads				Hex				
.12	.50	1/4-20	.75"	.20"	.16"	.25"	.40"	.09"	.50"	■
.25	1.25	3/8-16	1.13"	.30"	.25"	.38"	.75"	.14"	.75"	.13"
.50	2.00	1/2-13	1.50"	.40"	.31"	.50"	.75"	.19"	1.00"	.15"
.75	2.50	5/8-11	1.88"	.50"	.38"	.62"	.88"	.19"	1.25"	.18"

- No Thread Relief for 1/4-20 Series
- * Steel or Stainless Steel Versions Available
- * Available with Anti-Vibration Locking Patch

LANYARDS

- 47** Wire Rope Lanyards
- 48** Coiled Plastic Lanyards



Wire Rope Lanyards

Can be Made to Mil Spec Specifications

*Not Mil Spec Certified



Custom Lanyards & Arious Terminus Ends Available

Description	Type	Wire Material	Wire Diameter (+/- 1/64)	Jacket Material	Usable Length (Inches)	Termination A	Termination B
Loop/Loop 6"	1	Stainless	.047"	Nylon	6"	3/4" Loop	3/4" Loop
Loop/Loop 6"	1	Galvanized	.047"	PVC	6"	3/4" Loop	3/4" Loop
Eye/Eye 6"	3	Galvanized	.047"	PVC	6"	#10 Stake Eye	#10 Stake Eye
Loop/Eye 6"	2	Galvanized	.047"	PVC	6"	3/4" Loop	#10 Stake Eye
Loop/Tab 6"	4	Stainless	.047"	Nylon	6"	3/4" Loop	#10 Tab
Loop/Tab 6"	4	Galvanized	.047"	PVC	6"	3/4" Loop	#10 Tab
Loop/Loop 12"	1	Stainless	.047"	Nylon	12"	3/4" Loop	3/4" Loop
Loop/Loop 12"	1	Galvanized	.047"	PVC	12"	3/4" Loop	3/4" Loop
Eye/Eye 12"	3	Galvanized	.047"	PVC	12"	#10 Stake Eye	#10 Stake Eye
Loop/Eye 12"	2	Galvanized	.047"	PVC	12"	3/4" Loop	#10 Stake Eye
Loop/Tab 12"	4	Stainless	.047"	Nylon	12"	3/4" Loop	#10 Tab
Loop/Tab 12"	4	Galvanized	.047"	PVC	12"	3/4" Loop	#10 Tab

Mil Spec Lanyards

Description *NOT MS CERTIFIED*	Type	Wire Material	Wire Diameter (+/- 1/64)	Coated Diameter (+/- 1/64)	Jacket Material	Jacket Color	Usable Length (Inches)	Termination A	Termination B
Loop/Loop 6"	1	Stainless	.047"	.063"	Nylon	Green	6"	3/4" Loop	3/4" Loop
Loop/Eye 6"	2	Stainless	.047"	.063"	Nylon	Green	6"	3/4" Loop	#10 Stake Eye
Loop/Tab 6"	4	Stainless	.047"	.063"	Nylon	Green	6"	3/4" Loop	1/4" Tab
Loop/Loop 12"	1	Stainless	.047"	.063"	Nylon	Green	12"	3/4" Loop	3/4" Loop
Loop/Eye 12"	2	Stainless	.047"	.063"	Nylon	Green	12"	3/4" Loop	#10 Stake Eye
Loop/Tab 12"	4	Stainless	.047"	.063"	Nylon	Green	12"	3/4" Loop	1/4" Tab

- * Wire Material is 7X7 Aircraft Cable
- * Length is Measured Center Terminus to Center Terminus

Custom - Made to Order Available

Customize Your Own Lanyard by Choosing:

- Cable Diameter
- Cable Material (Steel or Stainless)
- Coated or Bare Wire
- Terminal Hardware (Loops, Tabs, Stake Eyes, Hooks, Balls, etc.)

Lanyards may be assembled onto Innovative's line of standard Quick Release Pins such as Positive Locking Pins, Detent Pins, Lynch Pins, and Wire Lock Pins.



Coiled Plastic Lanyards

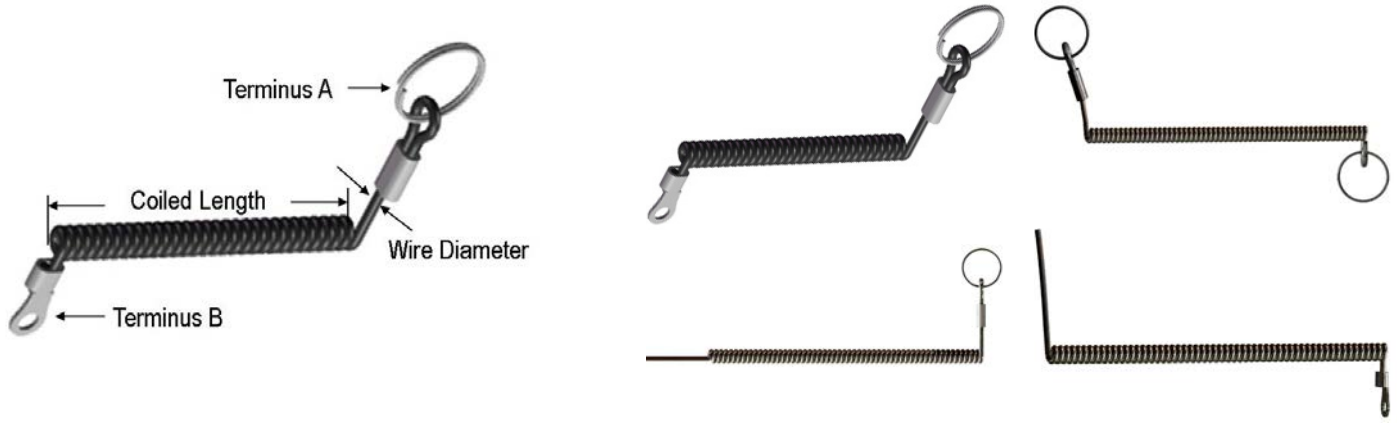

Diameter	Coiled Length	Terminal Hardware	Cross Radial Tail
.11"	6"	7/8" ID Welded Loop	✓
.11"	6"	#10 Stake Eye	✓
.11"	6"	5/16" Stake Eye	✓
.11"	6"	Split Ring #8	✓
.11"	6"	Single Split Ring	✓
.11"	6"	Double Split Ring	✓
.145"	5"	Split Ring, Welded Loop	✓
.145"	5"	1" ID Welded Loop	✓

HANDLES

50 Adjustable Handles

5



Adjustable Handles

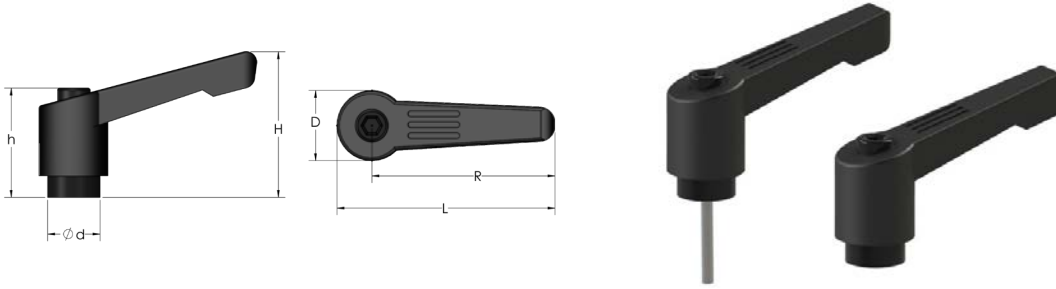

Standard Sizes

Part Number	L	R	H	D	d	h	d1
RH04----1.92BK38---H-23	1.92"	1.65"	1.32"	0.55"	0.39"	0.96"	10-24"
RH02----1.92BK38---H-23	1.92"	1.65"	1.32"	0.55"	0.39"	0.96"	10-32"
RH4C----1.92BK38---H-23	1.92"	1.65"	1.32"	0.55"	0.39"	0.96"	1/4-20"
RH4C----2.91BK38---H-23	2.91"	2.55"	1.79"	0.70"	0.53"	1.22"	1/4-20
RH5C----2.91BK38---H-23	2.91"	2.55"	1.79"	0.70"	0.53"	1.22"	5/16-18
RH5C----3.50BK38---H-23	3.50"	3.07"	2.12"	0.86"	0.62"	1.41"	5/16-18
RH6C----3.50BK38---H-23	3.50"	3.07"	2.12"	0.86"	0.62"	1.41"	3/8-16
RH6C----4.13BK38---H-23	4.13"	3.62"	2.51"	0.98"	0.74"	1.65"	3/8-16
RH8C----4.13BK38---H-23	4.13"	3.62"	2.51"	0.98"	0.74"	1.65"	1/2-13

Metric Sizes

Part Number	L	R	H	D	d	h	d1
RHM4----49MMBK38---H-23	49mm	42mm	33.5mm	14mm	10mm	24.5mm	M4
RHM5----49MMBK38---H-23	49mm	42mm	33.5mm	14mm	10mm	24.5mm	M5
RHM6----49MMBK38---H-23	49mm	42mm	33.5mm	14mm	10mm	24.5mm	M6
RHM6----74MMBK38---H-23	74mm	65mm	45.5mm	18mm	13.5mm	31mm	M6
RHM8----74MMBK38---H-23	74mm	65mm	45.5mm	18mm	13.5mm	31mm	M8
RHM8----89MMBK38---H-23	89mm	78mm	54mm	22mm	16mm	36mm	M8
RHM10----89MMBK38---H-23	89mm	78mm	54mm	22mm	16mm	36mm	M10
RHM10----105MMBK38---H-23	105mm	92mm	64mm	25mm	19mm	42mm	M10
RHM12----105MMBK38---H-23	105mm	92mm	64mm	25mm	19mm	42mm	M12

THREAD IDENTIFIERS

- 52** Miniature Combination Unit
- 52** Standard Combination Unit
- 52** Jumbo Combination Unit
- 52** Lug Unit
- 53** National Pipe Tapered Unit
- 53** National Pipe Straight Unit
- 53** British Standard Pipe Tapered Unit
- 53** British Standard Pipe Parallel Unit
- 53** International Standards Organization Pipe Unit

6



The Thread Detective® - A Thread Identifying Tool

The Thread Detective® is a precise and easy-to-use thread identifier for both nuts and bolts, consisting of gliding ROHS Steel identifiers strung on a wire lanyard. It is especially well suited for distinguishing between similar inch and metric threads. Permanent, easy to read size markings are laser etched into each stand off. Shatterproof, color coded polypropylene gauge dividers allow recognition between inch and metric strands at a glance.

Our Thread Detectives® are equipped with a 3-3/8" (85mm) ruler for measuring stud lengths. The ruler can be printed with your company or customer's information for promotional use.

Miniature Combination Unit*

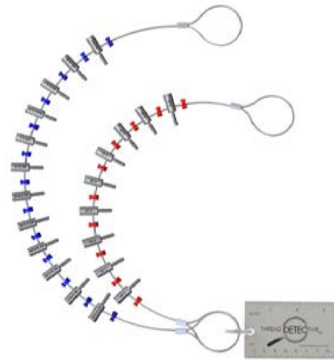

Standard (Inch) Identifiers consist of nut and bolt sizes of 1-64, 1-72, 2-56, 2-64, 3-48, 3-56, 4-40, 4-48, 5-40
Metric identifiers consist of nut and bolt sizes of M1.2 x 0.25, M1.6 x 0.35, M1.6 x 0.20, M1.8 x 0.35, M2 x 0.40, M2 x 0.25, M2.5 x 0.45, M2.5 x 0.35, M3 x 0.35, M3 x 0.50, M3.5 x 0.60, M3.5 x 0.35

Standard Combination Unit*

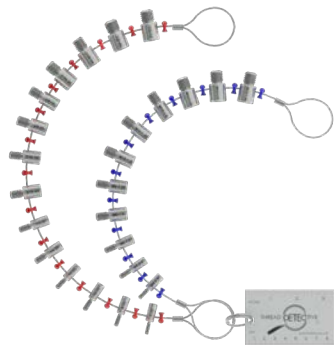

Standard (Inch) Identifiers consist of nut and bolt sizes of 6-32, 8-32, 10-24, 10-32, 1/4-20, 1/4-28, 5/16-18, 5/16-24, 3/8-16, 3/8-24, 7/16-14, 7/16-20, 1/2-13, and 1/2-20

Metric Identifiers consist of nut and bolt sizes of M4x0.7, M5x0.8, M6x1.0, M8x1.0, M8 x 1.25, M10 x 1.0, M10 x 1.25, M10 x 1.50, M12 x 1.25, M12 x 1.5, and M12 x 1.75

Jumbo Combination Unit*

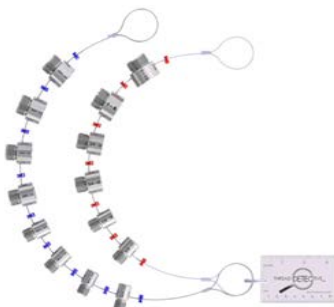

Standard (Inch) Identifiers consist of nut and bolt sizes of 5/8-11, 5/8-18, 3/4-10, 3/4-16, 1-8 & 1-12

Metric Identifiers consist of nut and bolt sizes of M14 x 1.5, M14 x 2.0, M16 x 1.5, M16 x 2.0, M20 x 1.5, M20 x 2.5, M24 x 2.0, M24 x 3.0

Lug Unit - For Lug Nuts / Bolts

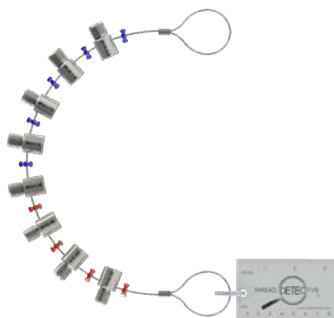

Standard (Inch) identifiers consist of nut and bolt sizes of 7/16-20, 1/2-20, 9/16-18

Metric Identifiers consist of nut and bolt sizes of M12 x 1.25, M12 x 1.5, M12 x 1.75, M14 x 1.5, M14 x 2.0

*All Combination Units are also Available in Standard (Inch) or Metric Only Strands.

Pipe Thread Detective®

Pipe Thread Detectives® are precise and easy to use thread identifiers for both male and female fittings. CNC machined identifiers glide on wire lanyards. They are especially well-suited for distinguishing between similar National, British and ISO pipe threads. Permanent, easy to read size markings are laser etched into each stand-off. Shatterproof, color-coded gauge dividers allow recognition of each strand at a glance.

Our Thread Detectives® are equipped with a 3-3/8" (85mm) ruler for measuring stud lengths. The ruler can be printed with your company or customer's information for promotional use. For your convenience, we provide extra long wire rope for those hard to reach places, as well as loops on each end for hanging.

National Pipe Tapered (NPT) Unit

National Pipe Tapered (NPT) Unit consists of sizes 1/8-27, 1/4-18, 3/8-18, 1/2-14, 3/4-14



National Pipe Straight (NPS) Unit

National Pipe Straight (NPS) Unit consists of sizes 1/8-27, 1/4-18, 3/8-18, 1/2-14, 3/4-14



British Standard Pipe Tapered (BSPT) Unit

British Standard Pipe Tapered (BSPT) Unit consists of sizes 1/8-28, 1/4-19, 3/8-19, 1/2-14, 3/4-14

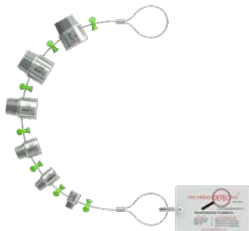

British Standard Pipe Parallel (BSPP) Unit

British Standard Pipe Parallel (BSPP) Unit consists of sizes 1/8-28, 1/4-19, 3/8-19, 1/2-14, 3/4-14

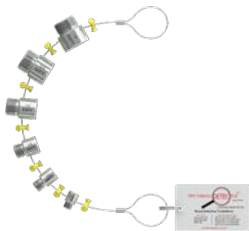

International Standards Organization (ISO) Pipe Unit

International Standards Organization (ISO) Pipe Unit consists of sizes M5x0.8, M8x1.0, M10x1.0, M12x1.5, M14x1.5, M16x1.5, M18x1.5, M22x1.5, M27x2.0

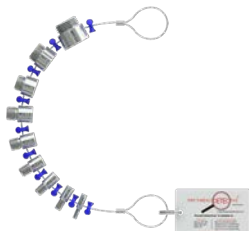

ENGINEERED COMPONENTS

55 CNC & Screw Machine Parts

56 Secondary Machining



CNC & Screw Machine Parts

Let Innovative Components show you how to achieve significant savings on your CNC & Screw Machine Parts by utilizing our low cost Costa Rican factory. Door to door transit times are less than 12 days.

Our low labor rates make prototypes and low to mid volume runs more affordable. Assemblies and parts requiring secondary operations are our specialty. Design services available.



Secondary Machining

Innovative Components is now specializing in secondary machining such as drilling, threading, shaving, and cutting. Our minimum order is \$250. Contact our Sales Team today for your quote regarding the following operations:

- Cut Off & Chamfer
- Cut Threading
- Cross Drilling
- Internal Tapping
- Turning
- Milling
- Shaving
- Grooving
- Pointing
- End Drilling

Cut Off & Chamfer



Cut Threading



Cross Drilling



Milling



Shaving



Grooving



Pointing



End Drilling



Turning





INNOVATIVE COMPONENTS, INC.

1050 National Parkway
Schaumburg, IL 60173
Phone: (800) 566-2774
Fax: (847) 588-9005
sales@knobsource.com

www.innovative-components.com