

REV.	SPECIFICATION	ECN NO.	APPD.
R6		ECN240516	

Material and Plating:

Housing: LCP, UL94V-0, Black.
Signal Contacts: Phosphor Bronze.
 Gold Plated on Contact Area and 80u" Min Tin Plated on Solder Tail over nickel 50u" Min .
Ground Contacts: Brass.
 Gold Plated on Contact Area and 80u" Min Tin Plated on Solder Tail over nickel 50u" Min .

Electrical Characteristics:

Current Rating: Signal: 3A Per Contact With 3 Adjacent Contacts (UL).
 Ground: 25A Per Contact With 1 Contact.
Voltage Rating: 125V AC .
Dielectric Withstanding Voltage: 525V AC For 1 minute.
Insulator Resistance: 5000MΩ min at DC 500V.
Contact Resistance: Signal: 45mΩ max .
 Ground: 15mΩ max .
Operating Temperature: -55°C ~ +125°C .
Durability: 250 Cycle .

***RoHS Compliant**

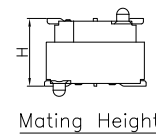
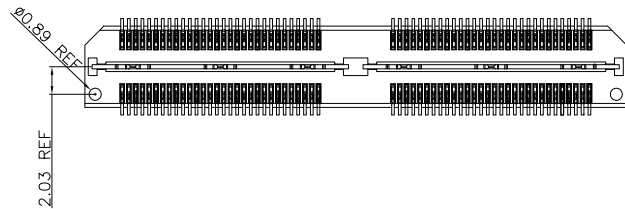
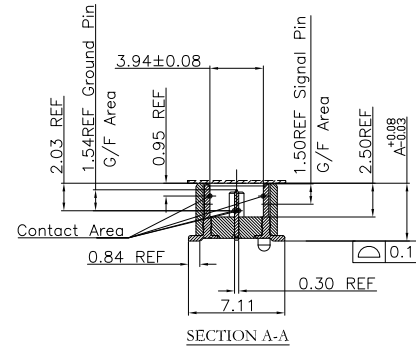
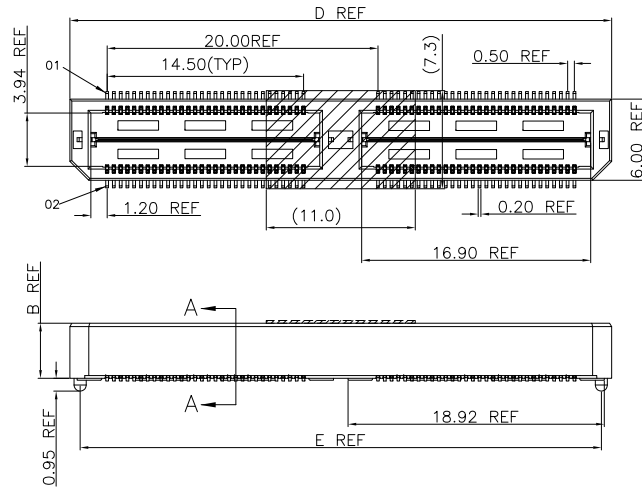

2384-A xx M C x D P x N x x T -x

Series: S: Mylar, Blank: Without Pad
 Position: T: Tape & Reel Package, U: Tube Package, A: Tray Package
 M: Male
 C: Selective Gold Plated
 2: 05u", 3: 10u"
 D: SMD Type
 N: W/O Post, P: With Post, Pl: Up & Down Post and P
 Blank: Without Friction lock, F: Friction lock, Blank: Without Guides, G: Guides Pin
 N: W/O Lock, L: With Lock(Press Fit), Ll: With Lock(Solder)
 Code 1~10

TABLE 2

Signaling (5mm Stack Height)	Speed Rating (No PCB Effect)
Single-Ended	9.5GHz/19Gbps
Differential	10.5GHz/21Gbps

TABLE 1

Code	A	B
1	4.267	4.064
2	7.267	7.064

TABLE 3

"*" Available Position

Code	Pos.	Dimension	
1		D	E
*	60	20.00	18.48
*	120	40.01	38.48

Code: 1~10 (A)	1	2	3	4	5	6	7	8	9	10
Male	4.267	7.267	10.267	15.243	18.240	21.237	24.237	29.238	13.269	14.270
Code: 1	1	1	1	1	1	1	1	1	1	1
Female	3.25	3.25	3.25	3.25	3.25	3.25	3.25	3.25	3.25	3.25
Mating Height(H)	5.00	8.00	11.00	16.00	19.00	22.00	25.00	30.00	14.00	15.00

Tolerances	Dwg. No.	2384-D0000-010
x = ±0.5	Projection	
.x = ±0.25	Unit	mm
.xx = ±0.15	Scale	1:1
	Drawn By	WP 05/11'24

Title: 2384-A Series
 High Speed Board to Board
 Pitch 0.5mm (Plug)

OUPIN
OUPIN ELECTRONIC(KUNSHAN) CO., LTD.
 P/N: 2384-AxxMCxDPxNxxT-x
 SHEET 1/6 Ver. No. R6

REV.	SPECIFICATION	ECN NO.	APPD.
R6		ECN240516	

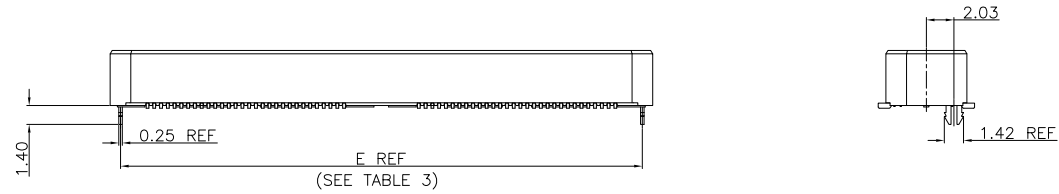

-L(With Lock)DIFFERENT AS SHOWN, OTHERWISE SAME AS SHEET 1

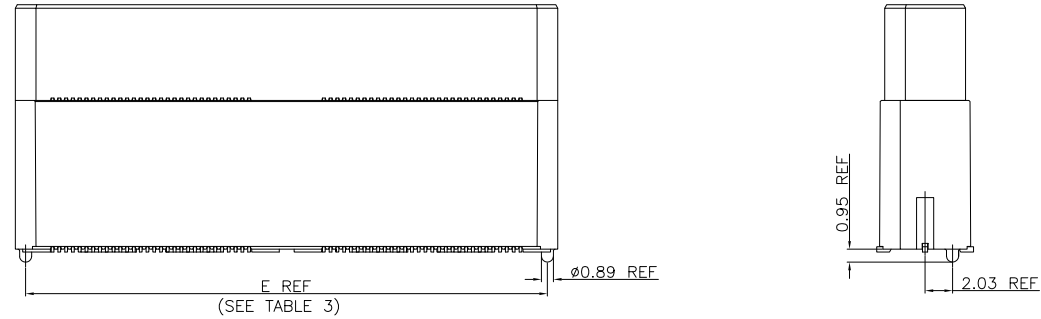

-P(With Post)DIFFERENT AS SHOWN, OTHERWISE SAME AS SHEET 1
(For Code 3 THRU Code 10, SEE TABLE 4.)

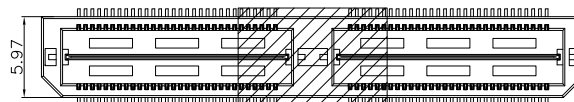
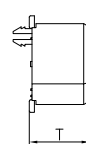

-S:Mylar

Code	T
1	4.47
2	7.47
3	10.47
4	15.45
9	13.47
10	14.47

Tolerances	Dwg. No.	2384-D0000-010		Title:	
x = ±0.5	Projection	⊕ ↗		2384-A Series	
.x = ±0.25	Unit	mm	Scale	1:1	
.xx = ±0.15	Drawn By	WP 05/11'24		High Speed Board to Board Pitch 0.5mm (Plug)	

Title:			
2384-A Series			
High Speed Board to Board			
Pitch 0.5mm (Plug)			

OUPIN			
OUPIN ELECTRONIC(KUNSHAN) CO., LTD.			
P/N: 2384-AxxMCxDPxNxxT-x			
SHEET	2/6	Ver. No.	R6

TABLE 4		
Code	SEE FIGURE	C OVERALL HEIGHT
3	1	10.269
4	1	15.243
5	2	18.240
6	2	21.237
7	3	24.237
8	3	29.238
9	1	13.269
10	1	14.270

REV.	SPECIFICATION	ECN NO.	APPD.
R6		ECN240516	

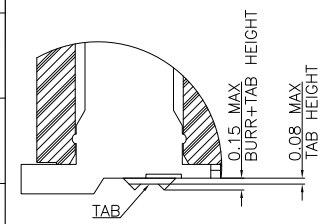

DETAIL E

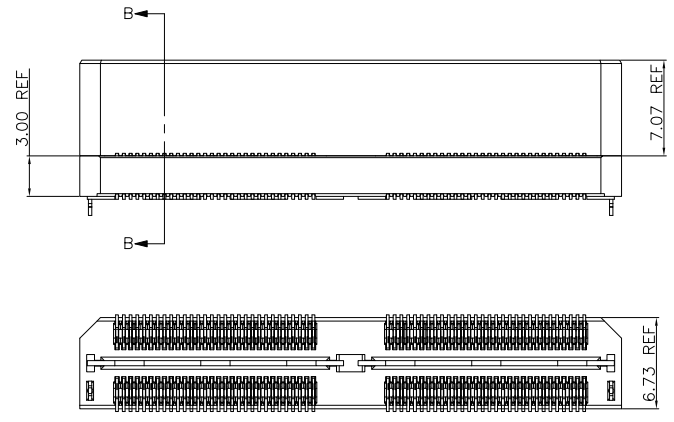

DIFFERENT AS SHOWN, OTHERWISE SAME AS SHEET 1

FIG 1

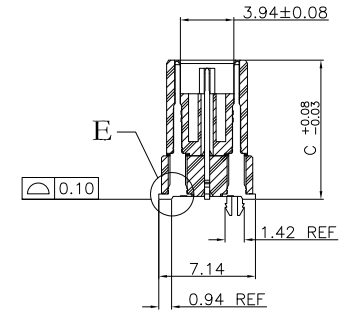

SECTION B-B

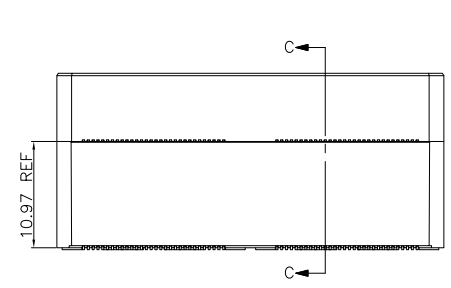

DIFFERENT AS SHOWN, OTHERWISE SAME AS -P

FIG 2

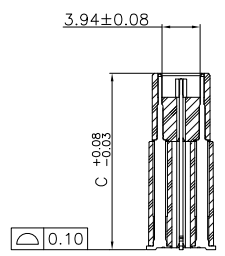

SECTION C-C
SCALE 1.25:1

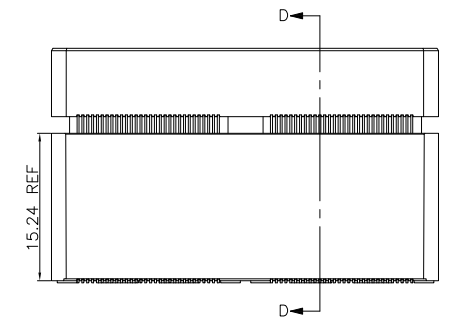

DIFFERENT AS SHOWN, OTHERWISE SAME AS -P

FIG 3

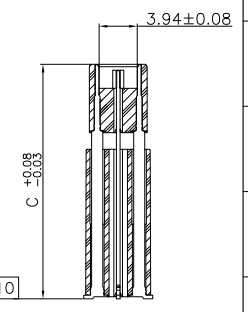

SECTION D-D
SCALE 1.25:1

Tolerances	Dwg. No.	2384-D0000-010		Title:	
x = ±0.5	Projection			2384-A Series	
.x = ±0.25	Unit	mm	Scale	1:1	High Speed Board to Board Pitch 0.5mm (Plug)
.xx = ±0.15	Drawn By	WP 05/11'24			



OUPIN ELECTRONIC(KUNSHAN) CO., LTD.

P/N: 2384-AxxMCxDPxNxxT-x

SHEET	3/6	Ver. No.	R6
-------	-----	----------	----

TABLE 7		
No OF POS	G	H
60	33.15	25.73
120	53.15	45.73

REV.	SPECIFICATION	ECN NO.	APPD.
R6		ECN240516	

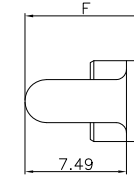
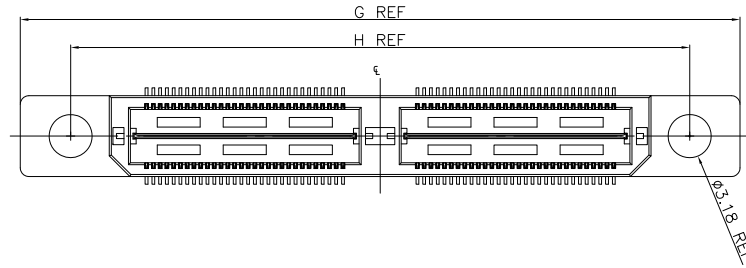

TABLE 6	
Code	F
1	9.220
2	12.220

-G(Guides Pin) DIFFERENT AS SHOWN, OTHERWISE SAME AS SHEET 1
(FOR Code1 & Code 2 LEAD STYLE ONLY)

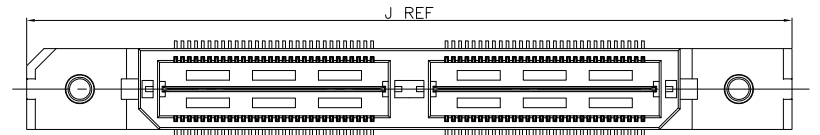
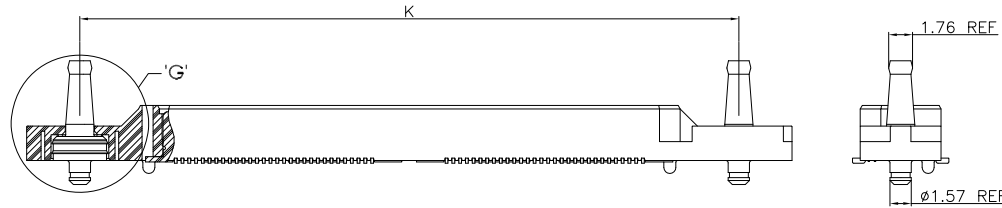
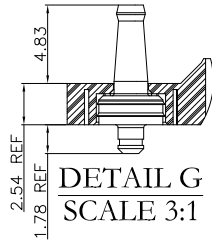

TABLE 8		
No OF POS	J	K
60	36.53	28.68
120	56.53	48.68



-P1(Up & Down Post and P) DIFFERENT AS SHOWN, OTHERWISE SAME AS SHEET 1
(FOR Code 1 LEAD STYLE ONLY)
(Not Available with -L(With Lock),-G(Guides Pin))

Tolerances	Dwg. No.	2384-D0000-010		Title:	
x = ±0.5	Projection			2384-A Series	
.x = ±0.25	Unit	mm	Scale	1:1	High Speed Board to Board
.xx = ±0.15	Drawn By	WP 05/11'24			Pitch 0.5mm (Plug)

OUPIIN ELECTRONIC(KUNSHAN) CO., LTD.			
P/N: 2384-AxxMCxDPxNxxT-x			
SHEET	4/6	Ver. No.	R6

REV.	SPECIFICATION	ECN NO.	APPD.
R6		ECN240516	

TABLE 9			
No OF POS	L	M	N
60	23.01	23.24	21.69
120	43.01	43.24	41.69

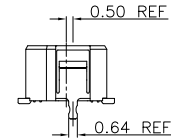
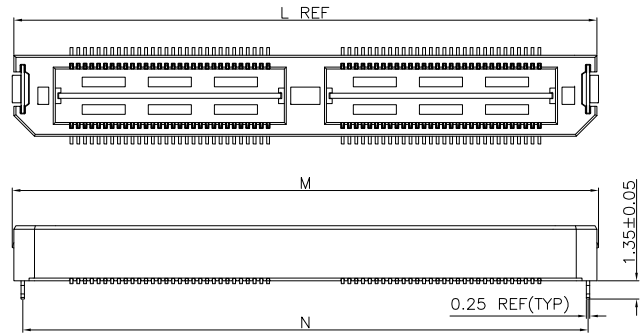

-L1(With Lock) DIFFERENT AS SHOWN. OTHERWISE SAME AS SHEET 1
 (FOR Code 1 LEAD STYLE ONLY)
 (Not Available with -L(With Lock),-G(GuidesPin),-F(Friction lock),or-P1(Up and Down Post) Options)

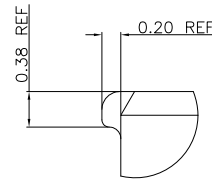
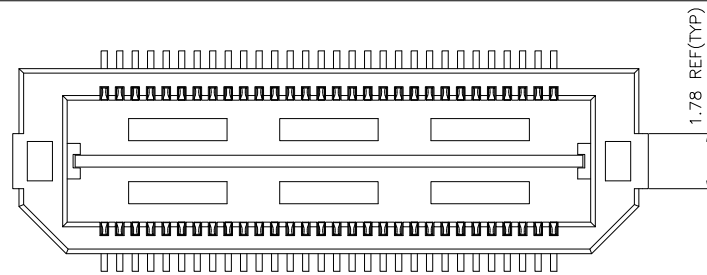

DETAIL "H"
SCALE 12:1

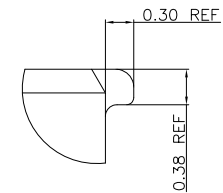

DETAIL "J"
SCALE 12:1

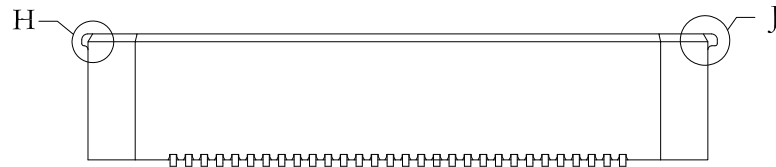

-F(Friction lock)
 (DIFFERENT AS SHOWN, OTHERWISE SAME AS SHEET 1)
 (Not Available with -G(Guides Pin) Options)

Tolerances	Dwg. No.	2384-D0000-010		Title:	
x = ±0.5	Projection			2384-A Series High Speed Board to Board Pitch 0.5mm (Plug)	
.x = ±0.25	Unit	mm	Scale		1:1
.xx = ±0.15	Drawn By	WP 05/11'24			

OUPIIN ELECTRONIC(KUNSHAN) CO., LTD.			
P/N: 2384-AxxMCxDPxNxxT-x			
SHEET	5/6	Ver. No.	R6

REV.	SPECIFICATION	ECN NO.	APPD.
R6		ECN240516	

Code	U
-01,-02	6.00
-03 THRU -10	6.73

OPTION	V
-L	1.19
-P	1.02

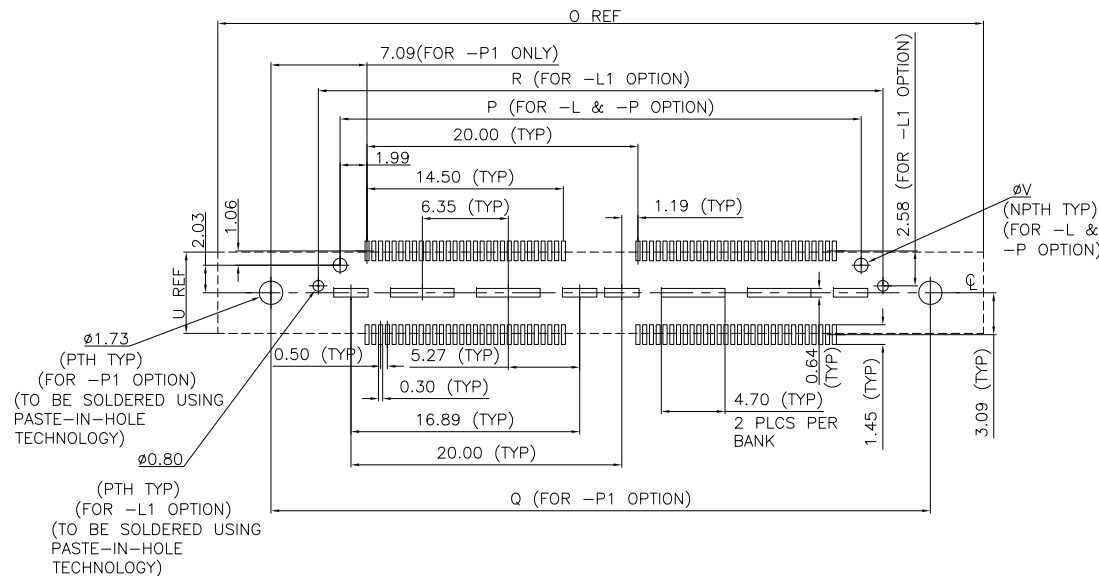

P.C.Board Layout
(Tolerance:±0.05)

No OF POS	O				P	Q	R	
	-L & -P	-F	-G	-P1	-L1	-L & -P	-P1	-L1
60	20.00	20.52	33.15	36.53	23.01	18.48	28.68	21.69
120	40.01	40.53	53.15	56.53	43.01	38.48	48.68	41.69

Tolerances	Dwg. No.	2384-D0000-010	
x = ±0.5	Projection		
.x = ±0.25	Unit	mm	Scale 1:1
.xx = ±0.15	Drawn By	WP 05/11'24	

Title:
2384-A Series
High Speed Board to Board
Pitch 0.5mm (Plug)

OUPIN
OUPIN ELECTRONIC(KUNSHAN) CO., LTD.
P/N: 2384-AxxMCxDPxNxxT-x
SHEET 6/6 Ver. No. R6